

DESCRIPTION	DATE	REV.
-------------	------	------

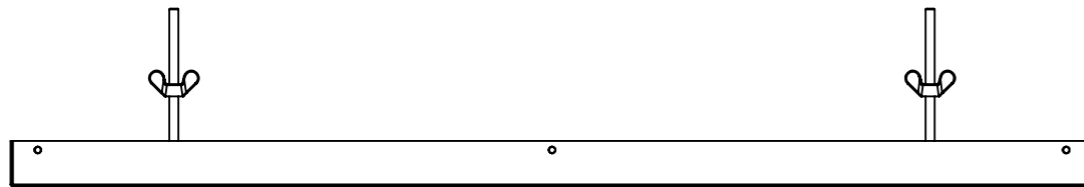

THESE BRACKETS CAN BE ALTERED AT 100mm CENTRES TO SUIT DESIGN OF LIFT CAR

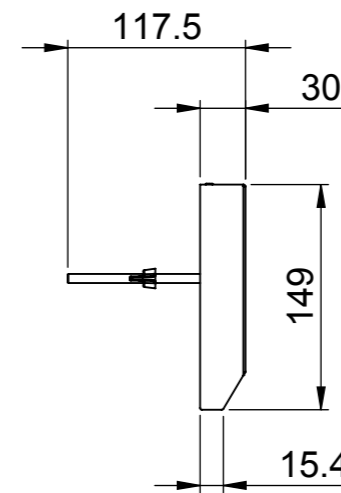
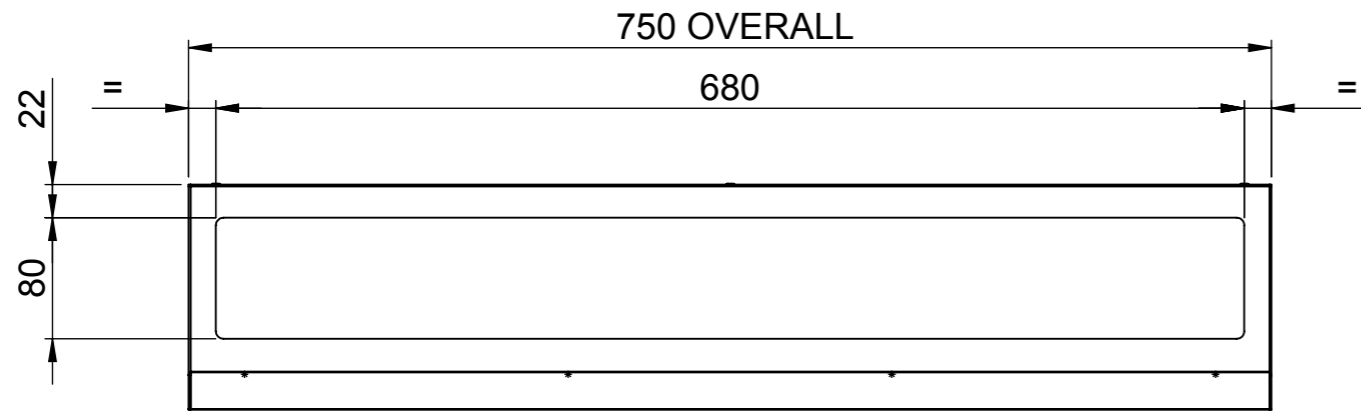
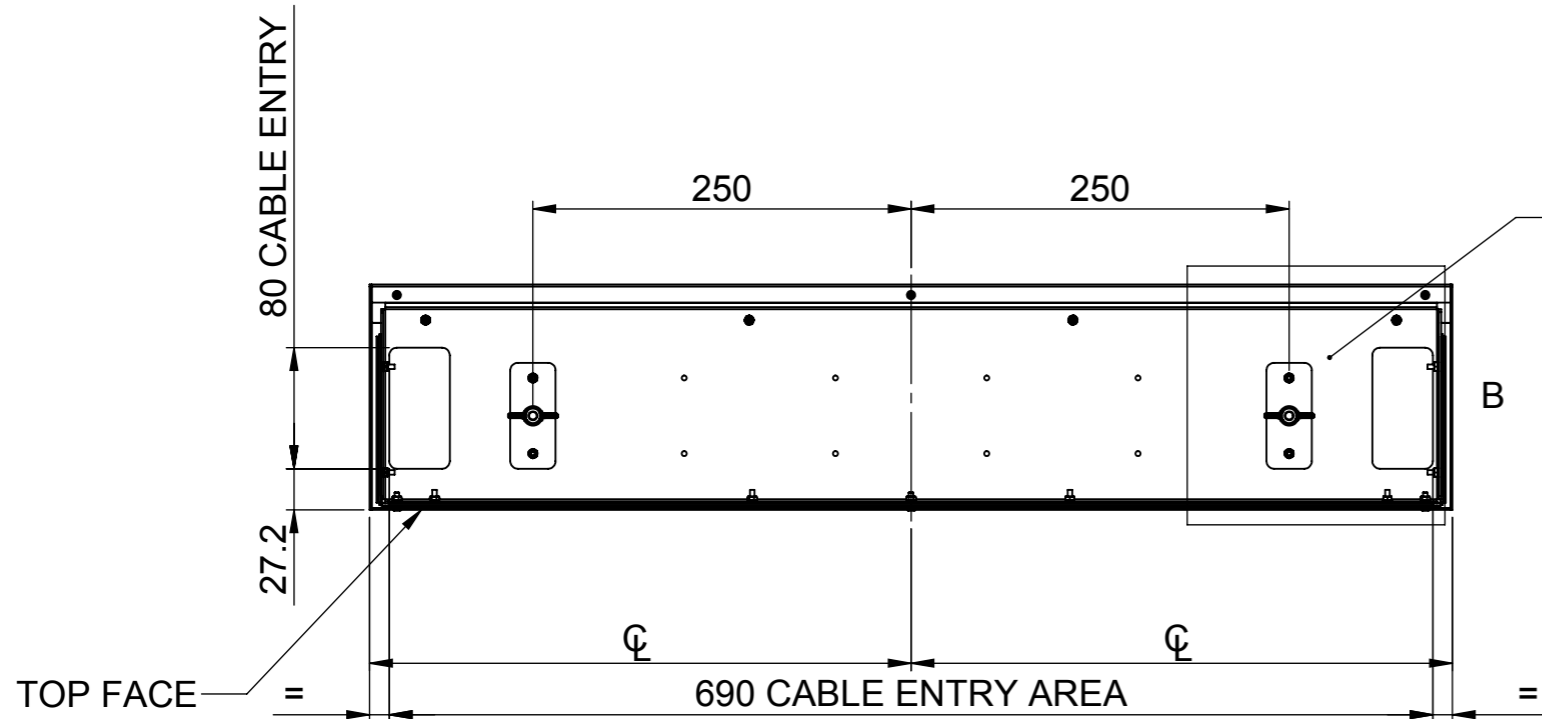

THE \varnothing 14mm CABLE ENTRY HOLE CAN BE DRILLED ANYWHERE IN THE DEFINED AREA

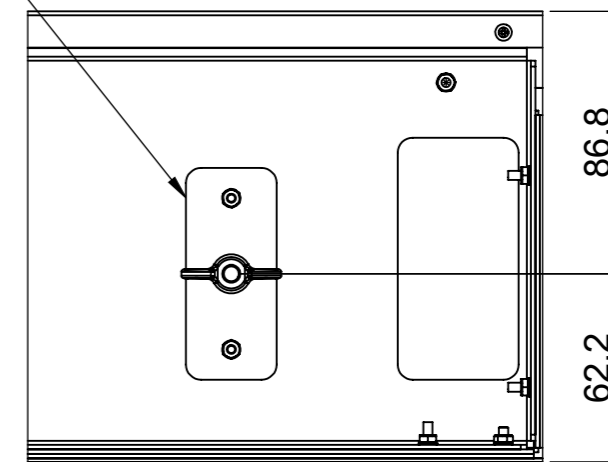

DETAIL B SCALE 2 : 5

MATERIAL: Galvanised & Grade 316 Satin ST/ST - 30 x 149 x 750 lg.

QUANTITY : AS REQUIRED

FINISH: Polished

	INTERNATIONAL LIFT EQUIPMENT GROUP WANLIP ROAD, SYSTON, LEICESTER LE7 1PD. TEL 0116 2690900 FAX 0116 2690939	TITLE : SMALL L.E.D SIDE LIGHT PL0683 750 x 149 OVERALL FOR : ? ?	PROPRIETARY AND CONFIDENTIAL THE INFORMATION CONTAINED IN THIS DRAWING IS THE SOLE PROPERTY OF INTERNATIONAL LIFT EQUIPMENT GROUP. ANY REPRODUCTION IN PART OR AS A WHOLE WITHOUT WRITTEN PERMISSION IS PROHIBITED	UNLESS OTHERWISE SPECIFIED DIMENSIONS ARE IN MILLIMETERS GENERAL TOLERANCES FOR SHEET METAL PARTS : \pm 0.5 mm GENERAL TOLERANCES FOR FABRICATED PARTS : \pm 1.5 mm	DATE 17/11/2011	WEIGHT 4.5Kg.	W.O. No *
					DRAWN <i>M. Miller</i>	PROJECTION	DRAWING No
				DO NOT SCALE DRAWING	MECH 108 D18	REV. *	