

INTERNATIONAL LIFT EQUIPMENT LTD

SKYCOM CAN-X

Installation Manual



FM 40432

London Tel: 0208 527 9669
London Fax: 0208 531 0936
Website: www.ileweb.co.uk

Leicester Tel: 0116 269 0900
Leicester Fax: 0116 269 0939
Email: service@ilegroup.co.uk

Contents

Introduction	4
System outline.....	4
System limitations	4
System nomenclature.....	4
Quick start kit	6
General do's and don'ts.....	6
Fitting the quick start kit.....	7
Preparing the control panel run on inspection	9
Mains connections	9
Braking resistor fitting and connections (traction only).....	9
Motor connections (traction).....	11
Motor connections (Hydraulic)	12
Motor encoder connections (traction).....	13
Machine connections (traction)	14
Valve connections (hydraulic)	15
Starting up both hydraulic and traction	16
Drive start up wizard (traction).....	18
Ready to run?	18
Main shaft loom and peripheral looms.....	18
General do's and don'ts.....	18
The hanger	19
Hanger installation	20
Loom tap off sockets.....	21
Correct tap off loom fitment.....	21
Top limit array connections	22
Lock connections.....	22
Pre lock connections (manual gates only).....	23
Bottom limit array connections	24
Pit safety circuit connections	24
Landing push connections, Landing indicator connections.....	25
Connecting the shaft loom to the controller.....	28
Motor room connections.....	28
Trailing flex.....	29
Car top I/O and looms	30
General do's and don'ts.....	31
Car top peripheral connections	32

Car top control and door gear connections32

Car gate switch, safety gear switch, car lights, load weighing and COP loom connections33

Door light ray and position system connections34

COP connections..... 35

Panel test connections..... 36

Technical support 36

Notes..... 37

Introduction

The Skycom CAN-X control system has been designed to speed up installation time by being supplied as standard with looms that include all shaft wiring, motor room wiring, trailing flex and car wiring. This system not only speeds up installation time thus reducing the down time for the customer it also cuts down on wiring errors as all looms are tested before leaving ILE's factory.

This manual outlines the correct procedure for connecting and installing these looms. For setting the drive up (traction lifts) see the Can-X Fuji drive manual.

System outline

The Skycom CAN-X control system is a distributed system. All I/O devices are local to their input or output, so the landing pushes have an I/O board mounted locally to them and the data from them is sent to the CAN-X CPU via a CAN cable (included in the loom). The same localisation of I/O is carried through to the car. The car top I/O and connections are housed within a custom halfway box and the I/O for the COP is pre-wired and fitted to a din rail to be mounted in the back of the COP. If the COP or landing push stations are bought from ILE these will be pre-wired and pre-addressed and will plug directly into the loom.

System limitations

- Standard shaft and trailing flex looms have been tested for 32 floors up to 125M length (with ILE indicators at each floor). Installations above these lengths may require special looms, available on request.
- For ease of installation we recommend the use of 75mm x 75mm trunking.
- Non ILE indicators are not catered for within the loom. If foreign indicators are to be fitted they have to be hard wired in accordance with their manufacturer's instructions.
- Alarm bell wiring is not included within the loom as it is not an EN81 requirement. We give the installer connections at the car top I/O unit and in the control panel for connecting an alarm bell if required.
- Connections for auto diallers or pit / car intercoms are not included in the loom (although the spare cores in the trailing flex could be used).
- Fixings are not included within the loom pack, neither are the trailing flex hangers. (these can be supplied separately)

System nomenclature

The drawings for the Skycom CAN-X control system are marked into 2 categories "E" for Electrical and "R" for Reference. E.g. C8259E7, C8259R2. Electrical drawings are the as wired drawings. Some of these drawings include external equipment for clarity but are generally how the control circuit is wired. It is these Electrical drawings that should be used for any fault finding. The drawing overleaf shows how to identify the different types of drawing.

THIS IS A REFERENCE DRAWING AND WOULD GENERALLY BE USED FOR CONNECTING THE LOOMS TO THE AUXILLARY EQUIPMENT AND CONTROL PANEL / CAR TOP I/O

INTERNATIONAL LIFT EQUIPMENT LIMITED	DRAWING No. R1	SHEET 6-11
	CONTRACT No. C12 7777	

THE CONTRACT NUMBER IS UNIQUE TO EACH CONTROLLER AND SHOULD BE QUOTED WHEN CONTACTING ILE FOR TECHNICAL SUPPORT

THIS IS AN ELECTRICAL DRAWING AND WOULD BE GENERALLY BE USED FOR FAULT FINDING THE CONTROL SYSTEM

INTERNATIONAL LIFT EQUIPMENT LIMITED	DRAWING No. E1	SHEET 2-11
	CONTRACT No. C12 7777	

The reference drawings are split into categories (car top, motor room e.t.c.) and should be used for connecting the looms to the auxiliary equipment and the controller / car top I/O. All of these reference drawings refer to connections on the main Electrical drawings.

The control panel's terminals are sectioned into zones all proceeding with an "X". On the drawings these are followed by the terminals nomenclature e.g. X19:L3. The car top's terminals are sectioned into zones proceeding with a "Y". 2 extra zones are allowed for we call these "XOP" and "YOP". These are for optional equipment on the controller (XOP) and the car top (YOP).

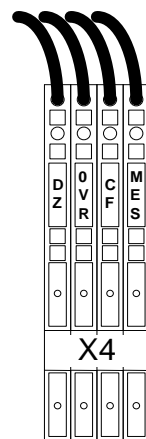

The diagram on the left shows a typical panel terminal rail section in this case X4

2 Rows of sockets for the loom plugs are available either can be used.

Quick start kit

A quick start kit is available and is supplied with the first controller(s) supplied to each company (extra quick start kits can be purchased). The quick start kit comes with pre-wired jumper plugs, to “bridge” out the safety circuits and limits, a pendant control with up, down and common buttons and a stop switch. **NOTE; The controller can be run in the conventional way by fitting the jumpers yourself and using the panel test unit or by fitting the car top I/O unit and wiring in the car top control. (see the relevant section of trailing and car top I/O fitting).**

NOTE; The condition of all jumper plugs and cables and the test unit cable should be checked prior to every installation and should be used in a controlled manner in line with your companies health and safety policy.

General do's and don'ts

- DO always plan ahead the cable runs into the machine / tank unit to make cable entry neater and EMC compliant.
- DO always plan the routing of cables to the machine / tank unit to offer the best possible mechanical protection.
- DO always follow your company's health and safety policy when working in a machine room.
- DO protect the controller equipment against swarf ingress when drilling the fixings for the controller.
- NEVER connect any of the car top, motor room or shaft equipment into a live controller.

Fitting the quick start kit

- Reel off the desired amount of cable from the reel (50M is supplied) and hang the pendant down the lift shaft. Lock off the cable so that the reel cannot accidentally unravel more cable.
- Plug the quick start pendant into **X5** on the controller terminal rail (there may be a panel test unit plugged into this id so remove it)

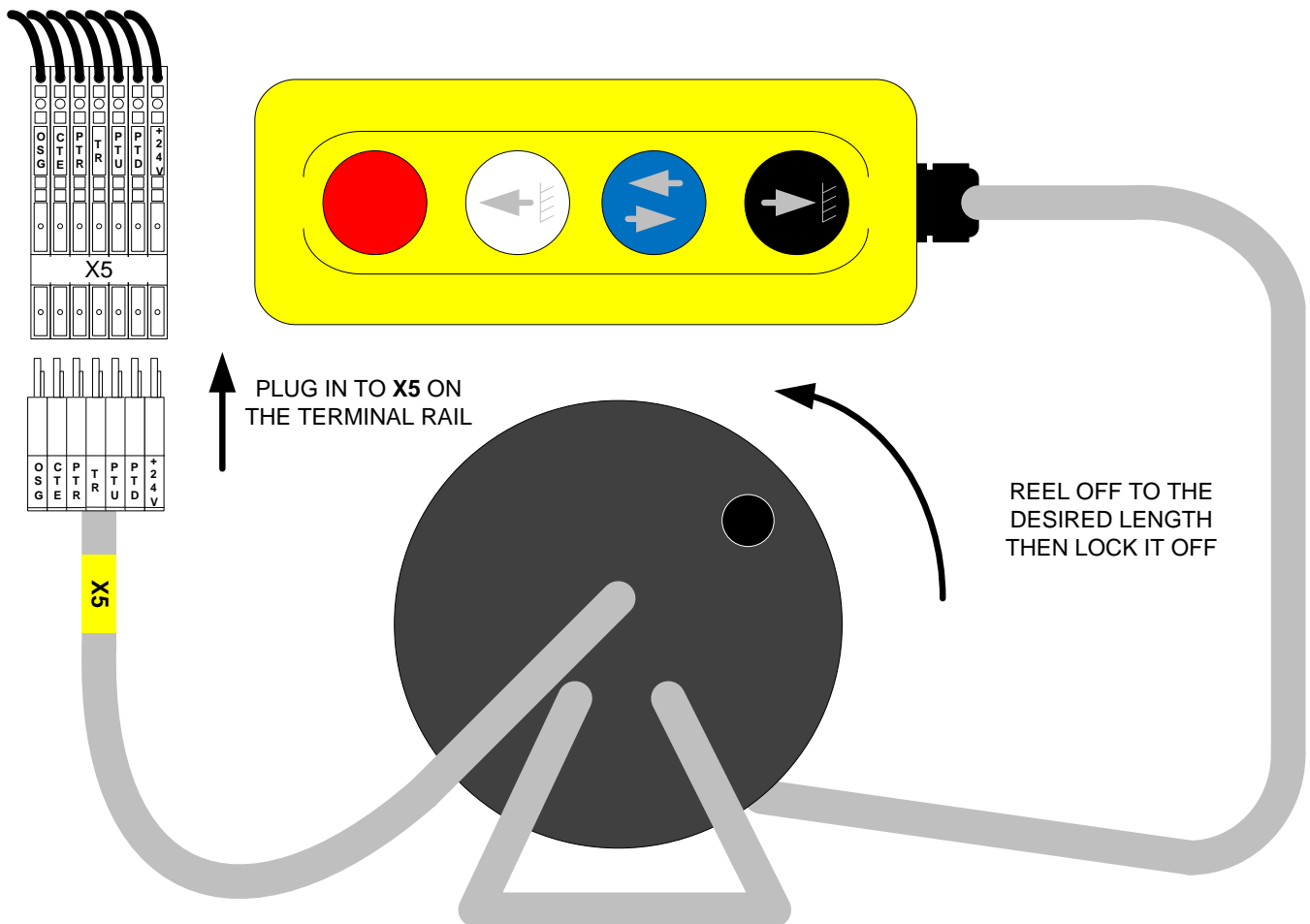

- Plug in the hand wind unit (see over the page)

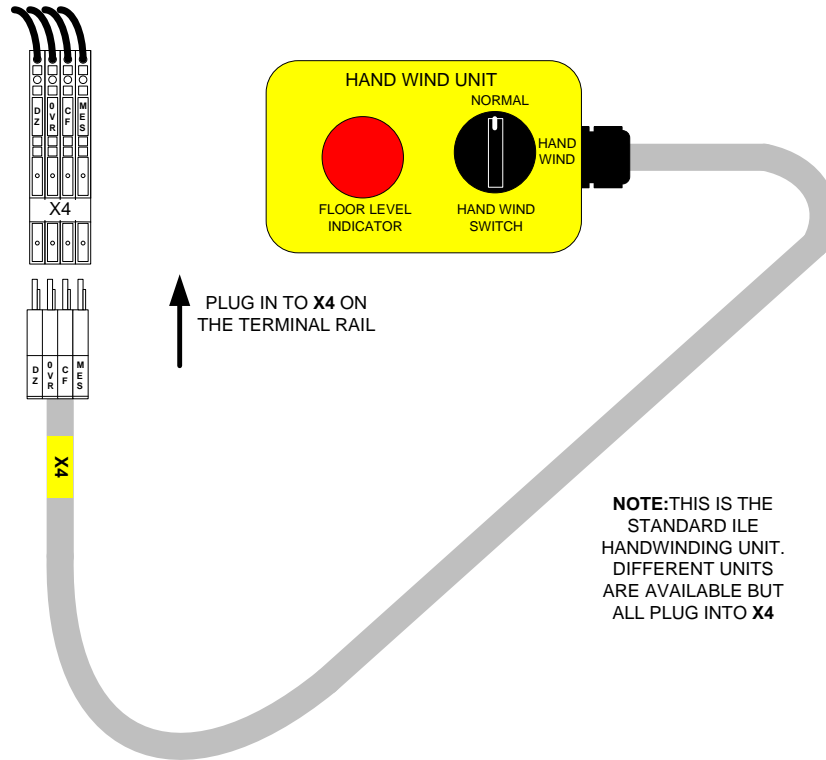

- Fit jumper plugs into **X8, 10, 11, 12** and **13** on the controller terminal rail as diagram below.

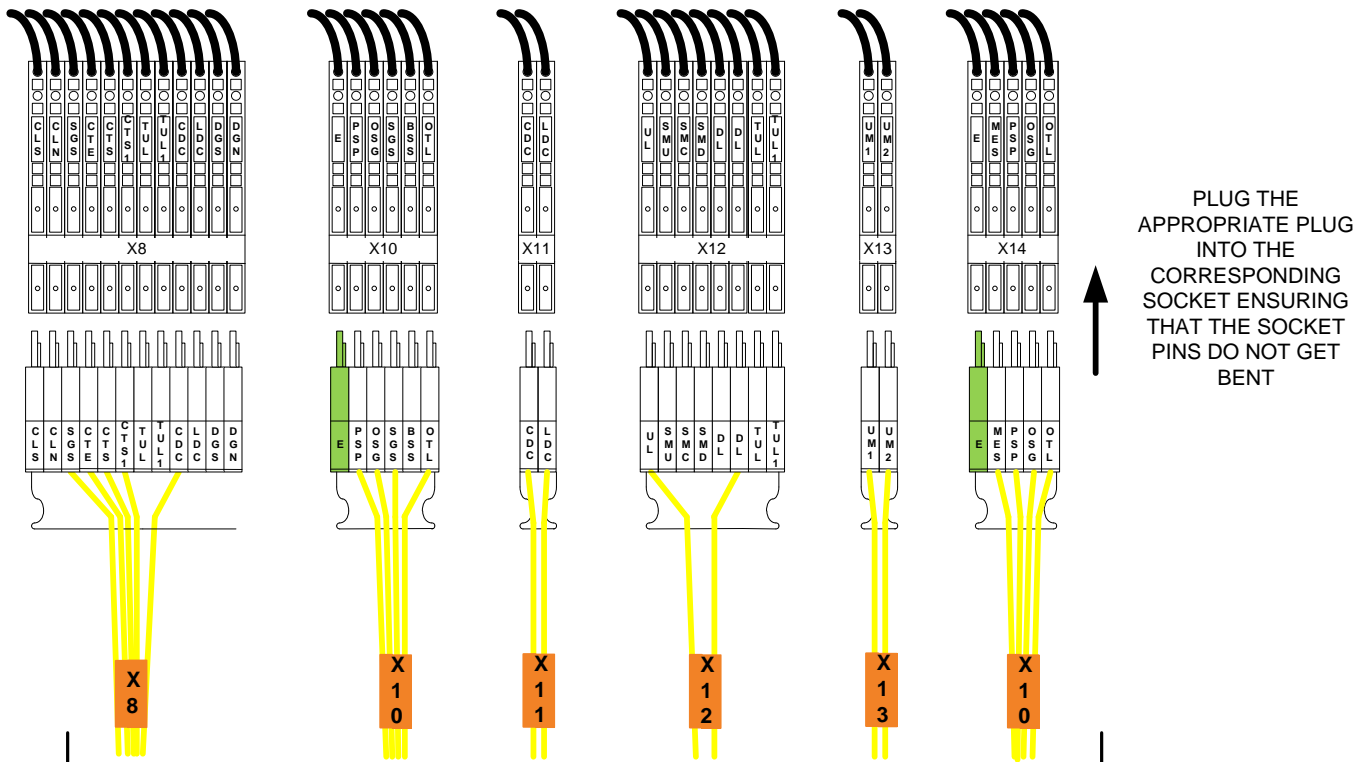

ALL JUMPER LEADS ARE 1m IN LENGTH

Preparing the control panel run on inspection

Once the quick start kit has been installed you need to connect the motor cables, mains cables, valve connections (hydraulic lifts), and brake connections (traction lifts).

Mains connections

The incoming mains are connected at the control panel terminal rail on both traction and hydraulic lifts at location **X17**. Traction lifts are supplied with a screened SY cable and Hydraulic lifts with single cables. The cable is cut to the length that was specified at the time of survey, if it is too long it can be cut to the desired length.

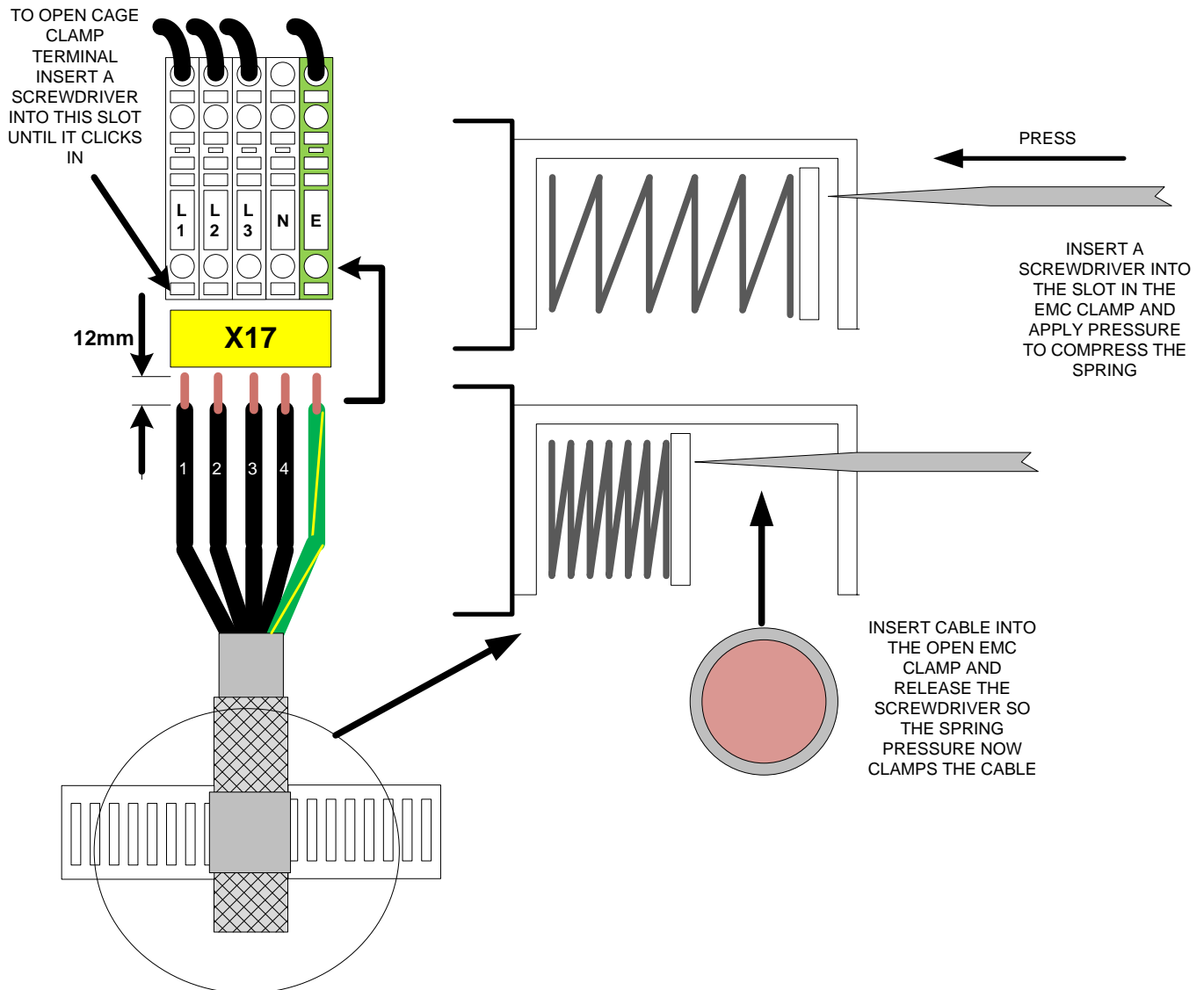

Braking resistor fitting and connections (traction only)

The braking resistor is connected at the control panel terminal rail at location **X18**. The braking resistor comes pre-wired (at the resistor end) with 3m of SY cable. The braking resistor should be mounted so the

heat can dissipate efficiently and that now other components around the resistor can be damaged by the heat. See diagram overleaf showing correct mounting and connections.

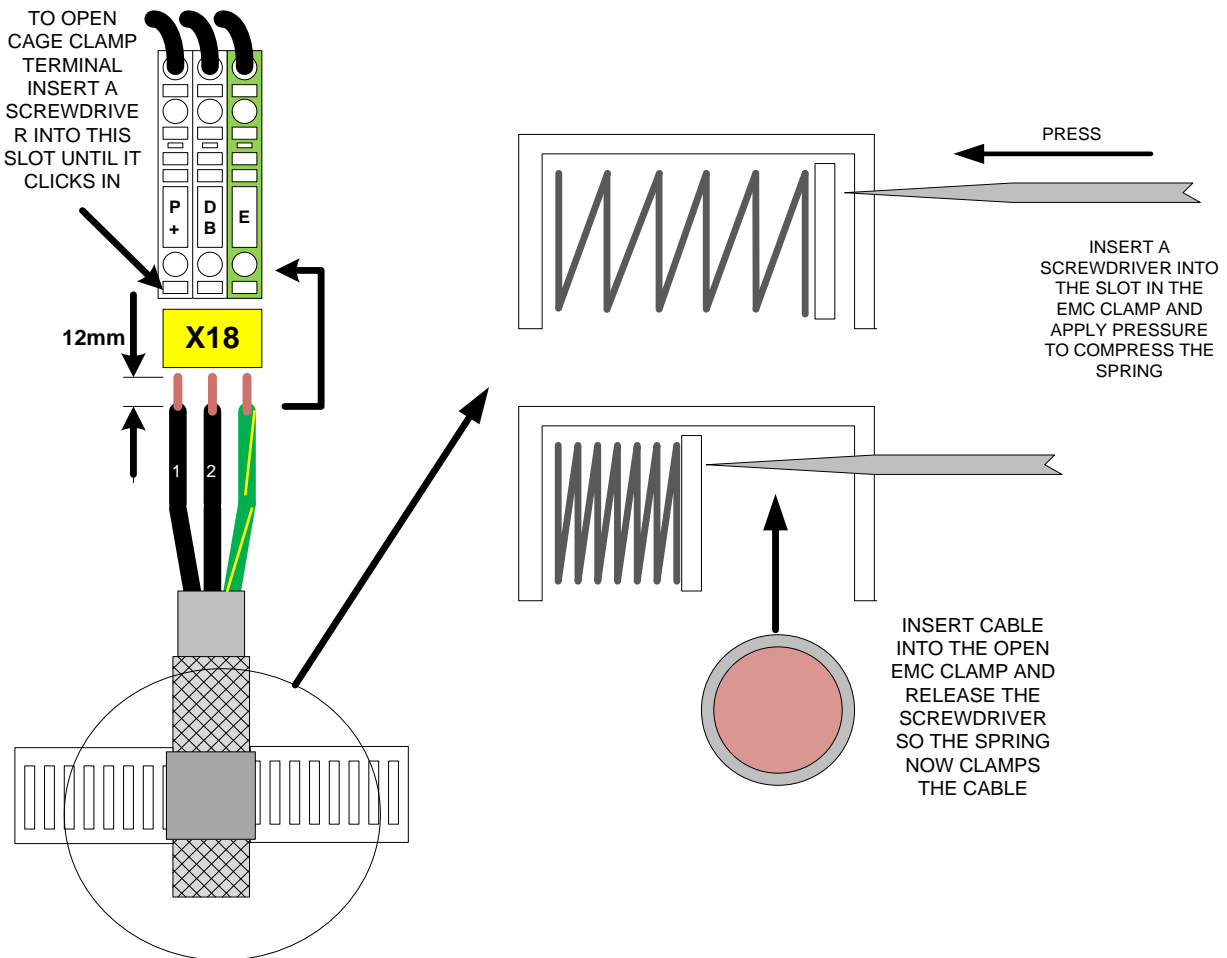

RESISTOR UNIT MOUNTING

HORIZONTAL OR VERTICAL MOUNTING
 NO CABLES OR TRUNKING WITHIN 1m OF HEAT SOURCE

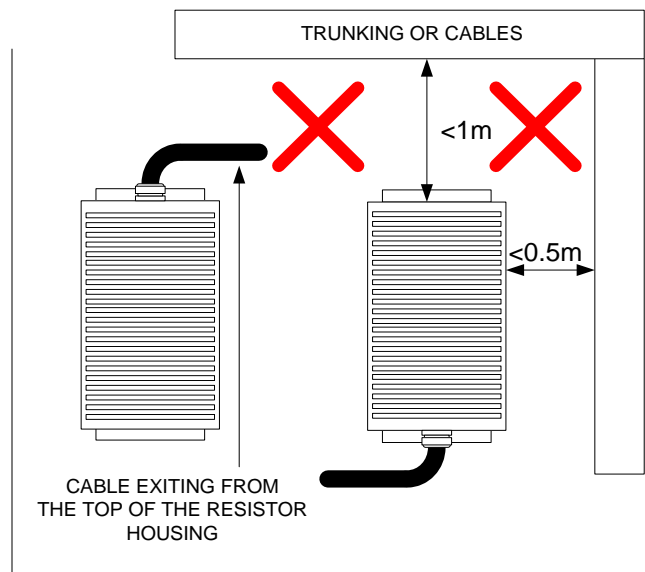
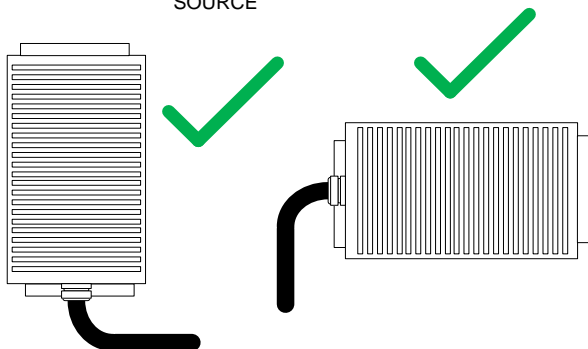

Motor connections (traction)

The motor SY cable is connected direct to the main contactor (MC). The motor cable is supplied cut to the length that was specified at the time of survey, if it is too long it can be cut to the desired length. Good EMC practise should be followed when routing this cable. (see EMC manual)

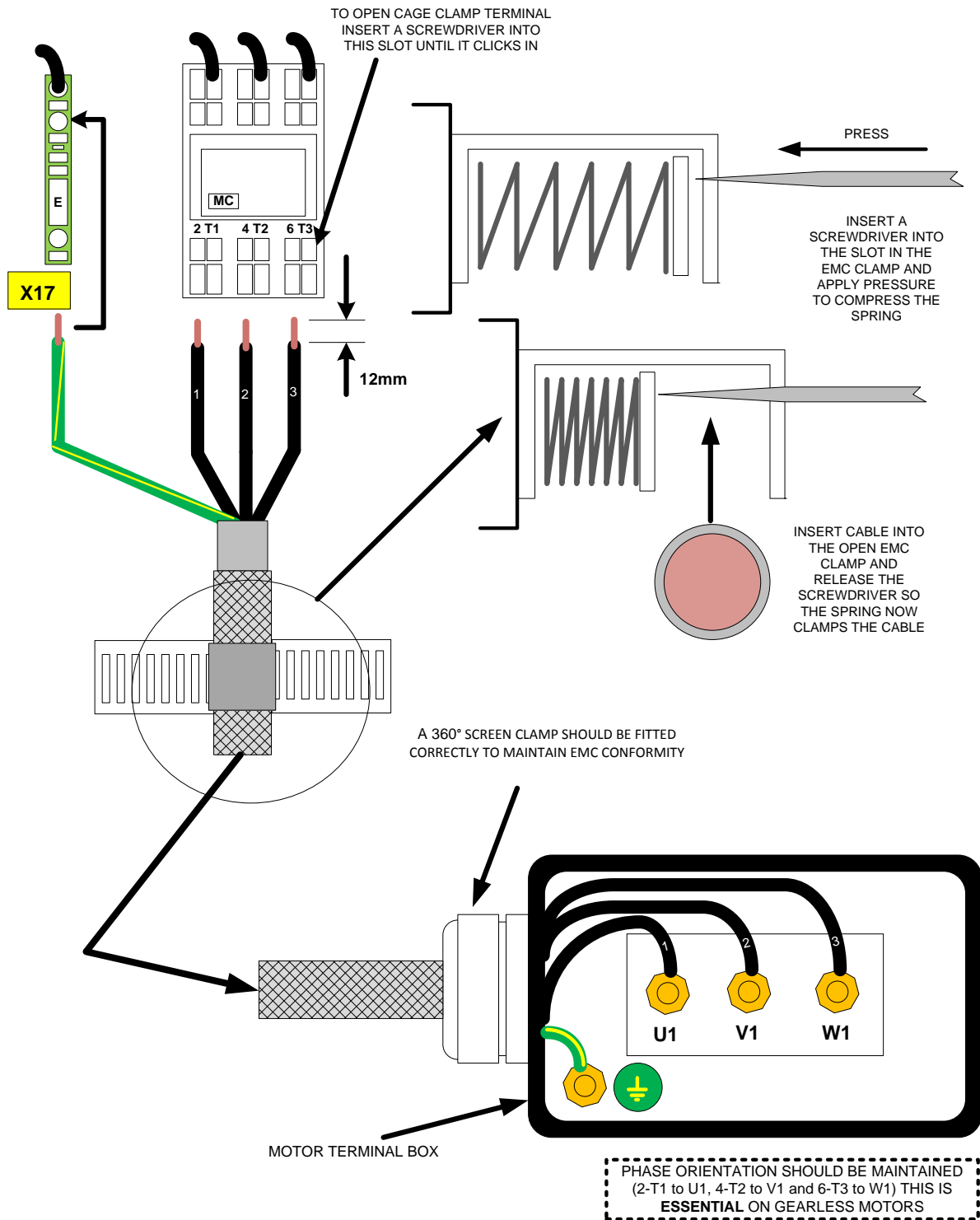

Motor connections (Hydraulic)

The motor wiring is connected at the control panel terminal rail at location **X18**. The motor cable is supplied cut to the length specified at the time of survey, if it is too long it can be cut to the desired length.

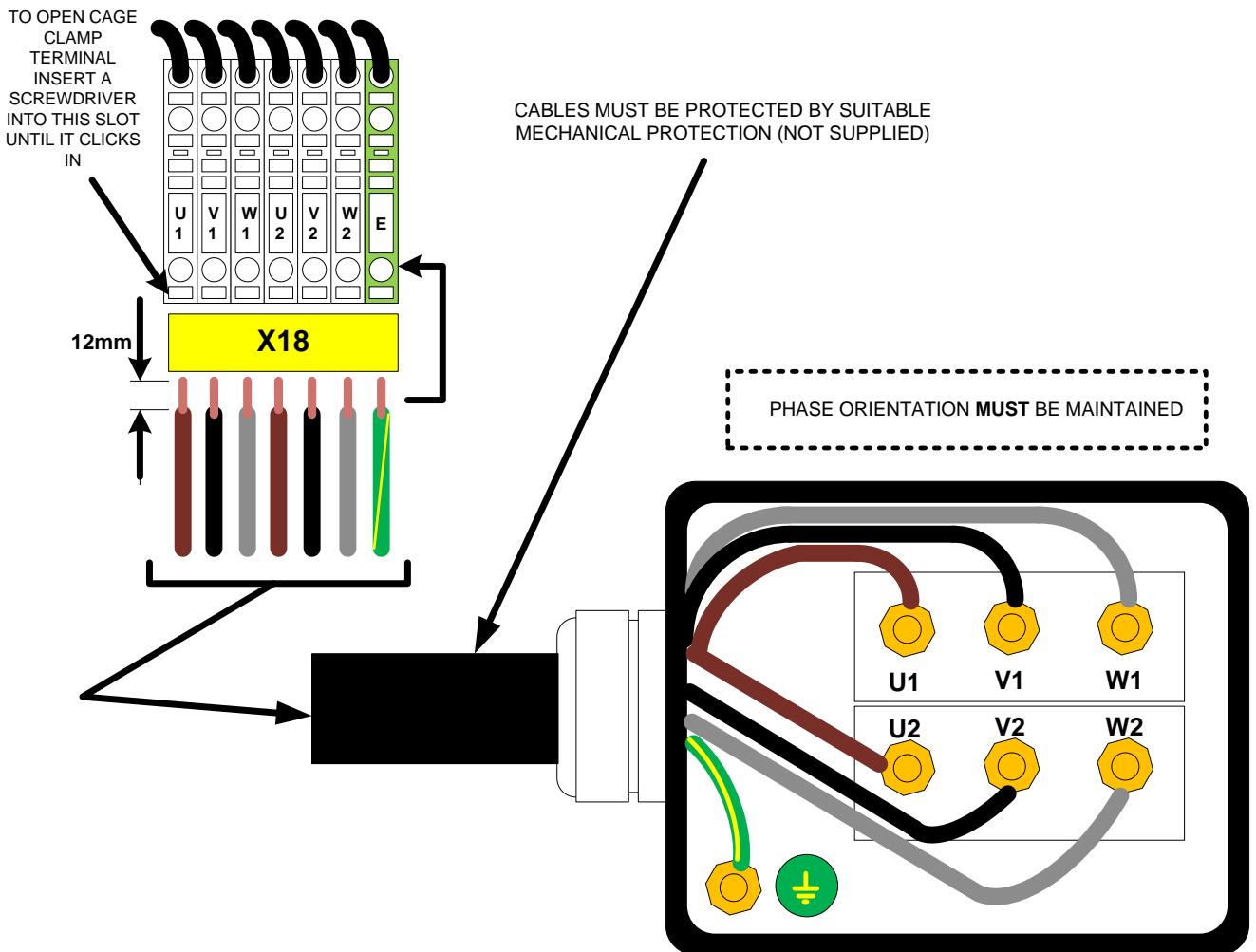

Motor encoder connections (traction)

The motor encoder wiring (if fitted) is connected directly to the drive and the screen should be connected to the chassis of the drive. Refer to the R1 drawing (motor room and trailing flex connections) for the correct connections for the type of encoder specified for your installation. Further information on encoder connections can be found in the ILE Fuji drive manual. Follow steps 1-5 below.

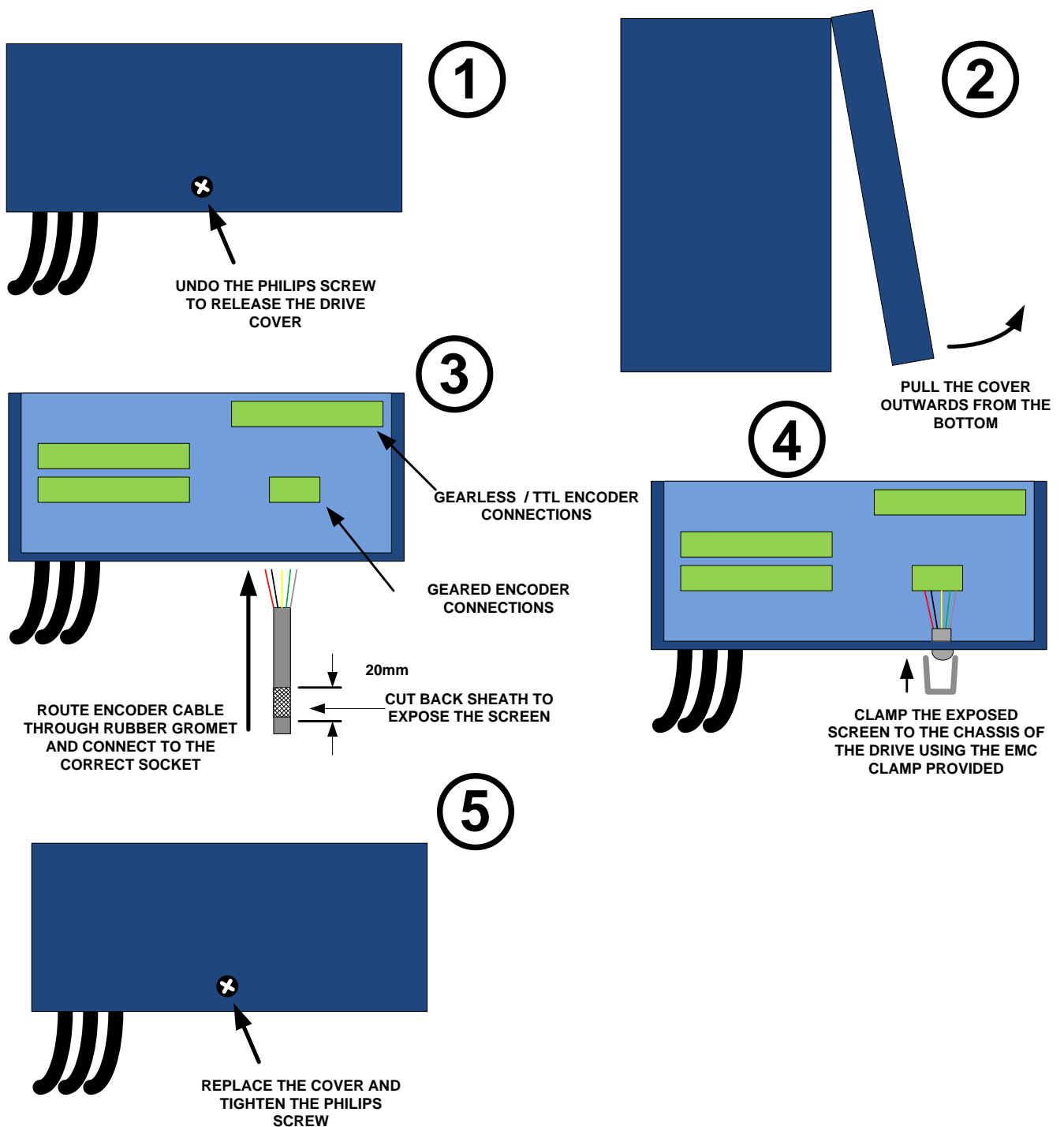

Machine connections (traction)

The motor control wiring (brake, thermistor e.t.c) are connected at the control panel terminal rail at location **X15**. The motor control cable is supplied cut to the length specified at the time of survey, if it is too long it can be cut to the desired length. The part number for this loom is PL1337. The loom is pre-prepared for motor fan, brake switches, thermistors and 2 brake coils. If any item in the loom is not required the cable should be removed and discarded.

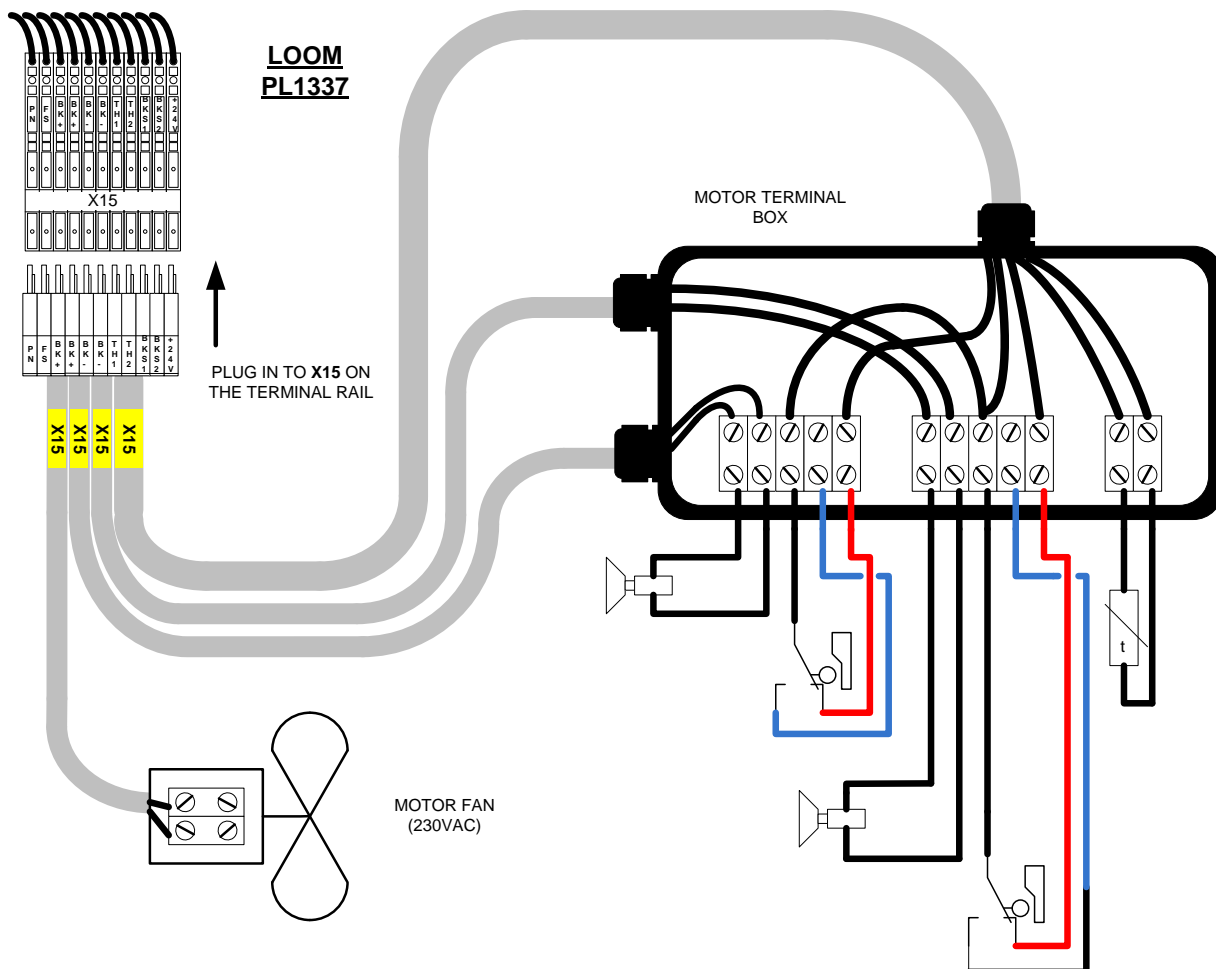

The diagram above is for guidance only and is shown wired in compliance with EN81-1 with A3. The cables are connected as follows and should be connected in conjunction with the **R1** drawing.

5 core cable marked MOTOR THERMISTORS & BRAKE SWITCHES should be wired as follows;

- Core 1 – TH1 one connection of the motor thermistor.
- Core 2 – TH2 the other motor thermistor connection.
- Core 3 - +24V connection for the brake switches.
- Core 4 – BKS1 connection for the brake switches.
- Core 5 – BKS2 connection for the brake switches (EN81-1 with A3 monitoring via drive).

2 core cable marked MOTOR FAN SUPPLY should be wired as follows;

- Core 1 – FS 230VAC Live connection to the motor fan circuit (see motor manufacturers instructions for connections).
- Core 1 – PN 230VAC Neutral connection to the motor fan circuit (see motor manufacturers instructions for connections).

2 core cable marked BRAKE COIL 1 and should be wired as follows.

- Core 1 – BK+ Positive feed to the first brake coil.
- Core 2 – BK- Negative feed to the first brake coil.

2 core cable marked BRAKE COIL 2 and should be wired as follows.

- Core 1 – BK+ Positive feed to the first brake coil.
- Core 2 – BK- Negative feed to the first brake coil.

Valve connections (hydraulic)

The valve control wiring (valves, thermister e.t.c) are connected at the control panel terminal rail at location **X15**. The valve control cable is supplied cut to the length specified at the time of survey, if it is too long it can be cut to the desired length.

The valve cable is not detailed below because each valve type has an individual loom manufactured for it. Please refer to the **R1** drawing for further details.

Starting up both hydraulic and traction

The supply can now be turned on. The initial checks that follow should be carried out before going any further. See the step by step guide below and over the page.

1

CHECK FOR ALL 3 LED'S ON THE PFRR.

U=POWER SUPPLY PRESENT (GREEN LED)

TC=THERMISTORS OK (RED LED)

R=PHASES PRESENT AND ROTATION OK (RED LED)

IF ALL LED'S LIT UP GOTO THE NEXT SECTION

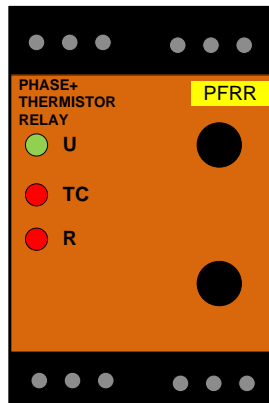

2

U NOT LIT UP

CHECK VOLTAGE BETWEEN AT CONTROLLER TERMINAL RAIL X17

L1-L2
 L2-L3 ALL 400V or ABOVE
 L1-L3

L1-E
 L2-E ALL 230V or ABOVE
 L3-E

IF ALL VOLTAGES ARE OK CHECK CB1 CIRCUIT BREAKER IS IN THE START POSITION IF IT IS OK CONTACT ILE TECHNICAL SUPPORT

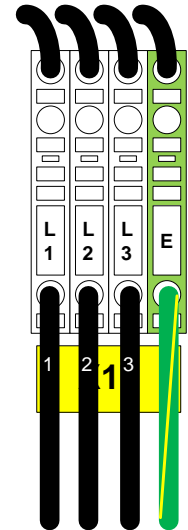

3

TC NOT LIT UP

CHECK THERMISTORS ARE CONNECTED CORRECTLY AT CONTROLLER TERMINAL RAIL X15 TH1 AND TH2

IF THERMISTORS ARE NOT FITTED IN THE MOTOR A RESISTOR (SUPPLIED) MUST BE FITTED ACCROSS TH1 & TH2

IF ALL ARE OK CONTACT ILE TECHNICAL SUPPORT

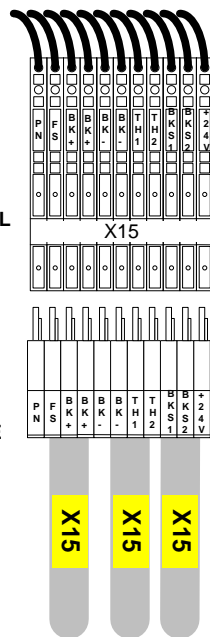

4

R NOT LIT UP

ISOLATE THE SUPPLY

SWAP ANY 2 PHASES AT CONTROLLER TERMINAL RAIL X17

L1 and L2
 Or
 L2 AND L3
 Or
 L1 and L3

TURN ON THE SUPPLY

IF R IS STILL NOR LIT UP CONTACT ILE TECHNICAL SUPPORT

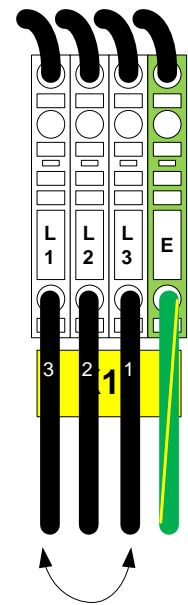

5

CHECK FOR ALL 5 LED'S ON THE SSR'S (3rd RAIL DOWN ON THE CONTROL PANEL)

IF ALL LIT UP PROCEED TO THE NEXT CHAPTER

LED'S

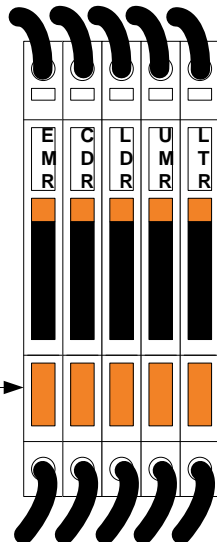

6

IF NO LEDS ARE LIT UP CHECK THE SUPPLY VOLTAGE AT F1 (110VAC)

CONNECT YOUR METER BETWEEN THE TOP TEST POINT AND EARTH

IF VOLTAGE IS PRESENT PROCEED TO STEP 7

IF NO VOLTAGE IS PRESENT PROCEED TO STEP 9

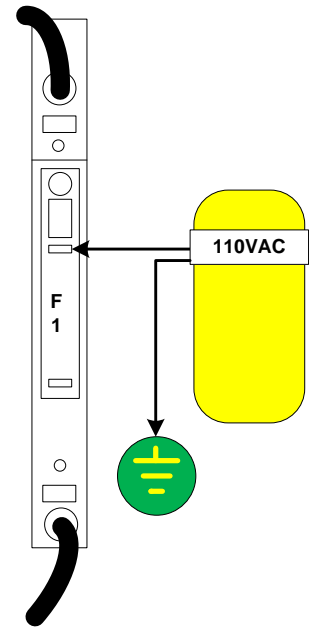

7

CONNECT YOUR METER BETWEEN THE BOTTOM TEST POINT AND EARTH

IF VOLTAGE IS PRESENT PROCEED TO STEP 8

IF NO VOLTAGE IS PRESENT CHECK THE FUSE AND IF THE FUSE IS OK PROCEED TO STEP 9 IF NOT CHANGE THE FUSE WITH THE CORRECTLY RATED FUSE AS SHOWN ON DRAWING E1

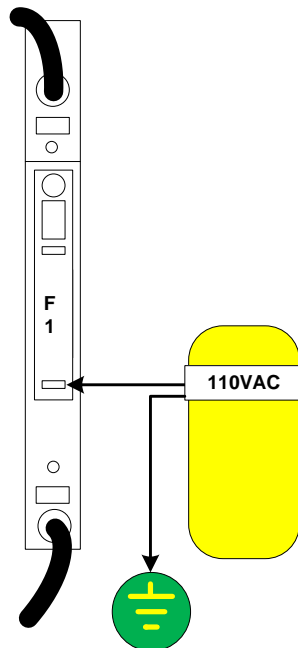

8

CONNECT YOUR METER BETWEEN NUMBER 2 ON THE BOTTOM R/H CORNER OF THE CPU AND EARTH

IF VOLTAGE IS PRESENT

PROCEED TO STEP 9

IF VOLTAGE IS NOT PRESENT CONTACT ILE TECHNICAL SUPPORT FOR ADVICE

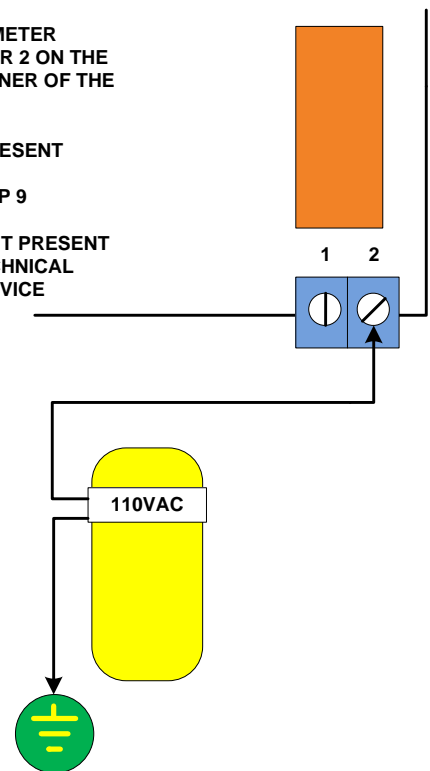

9

CHECK THE FOLLOWING ITEMS;

- CHECK CB1 CIRCUIT BREAKER IS IN THE START POSITION
- ARE YOU SURE ALL 3 LED'S ARE LIT ON THE PFRR (PHASE FAILURE AND THERMISTOR UNIT)?
- ARE YOU SURE ALL THE JUMPER LEADS ARE CONNECTED AS PER THE INSTRUCTIONS?
- IS THE HAND WINDING SWITCH SET TO NORMAL?
- IS THE STOP SWITCH ON THE PENDENT SET IN THE NORMAL POSITION?

IF THE ANSWERS TO ALL THE ABOVE ARE YES, PLEASE CONTACT ILE TECHNICAL SUPPORT FOR ADVICE.

Drive start up wizard (traction)

Before trying to run a traction lift the drive needs setting up with all the site and motor data. This is done by the drive start up wizard. See the “start up via the wizard” section of the Can-X Fuji drive manual.

If we supplied the motor the wizard data may have already been entered and the motor tune completed. Check the front panel of the drive, there will be a label stating whether the set up wizard has been completed or not. See below.

Ready to run?

If all the steps in this section have been completed correctly the lift should now be running on the quick start kit pendent.

NOTE: The lift is running with no safety circuits connected (except the pendent stop) so all the following operations should be carried out in a controlled manner to your company’s health and safety policy. If in doubt consult your H&S department.

If the lift is not running after this stage or you are unsure about any of the stages so far please contact ILE technical support.

Main shaft loom and peripheral looms

The shaft loom and its connections are prepared from either a survey by a member of ILE’s technical team or by the lift company using our data sheet (CDS9). 3 or 6 way tap off connections for the peripherals are fitted to the loom at the heights corresponding to this survey. From these tap off points all connections to the peripherals are made.

The loom is pre-marked with a hanger position which the loom is referenced from. This position corresponds to 2.5m above the top floor finished floor level.

Please ensure all looms are wired at the destination end BEFORE connecting to the controller terminal rail.

NOTE: It is imperative the loom is hung from this level. If it is not hung from this level the loom tap off points could be in the wrong position and the loom could be too long or too short.

NOTE: it is recommended that the loom is dropped before any of the peripheral looms are fitted and cut (if necessary) to length.

General do’s and don’ts

- DO always plan ahead the cable runs into the control panel to make cable entry neater.
- DO always plan the routing of cables into the shaft to offer the best possible mechanical protection.
- DO always follow your company’s health and safety policy when working in a machine room.
- DO protect the controller equipment against swarf ingress when drilling the fixings for the controller.
- NEVER connect any of the car top or shaft equipment into a live controller.
- NEVER leave any undue strain on the cables once fitted to the control panel. (See diagram overleaf)

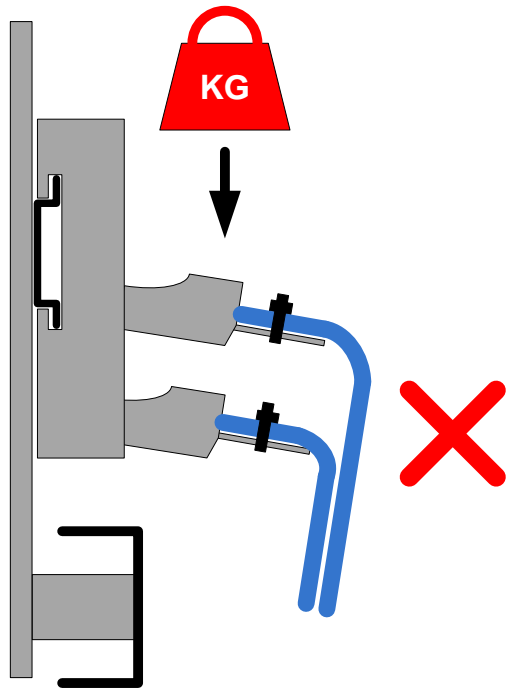

!!! PLUGS SHOULD NOT BE LEFT SO THE WEIGHT OF THE CABLE CAN CAUSE UNDUE PRESSURE ON THE CONNECTION **!!!**

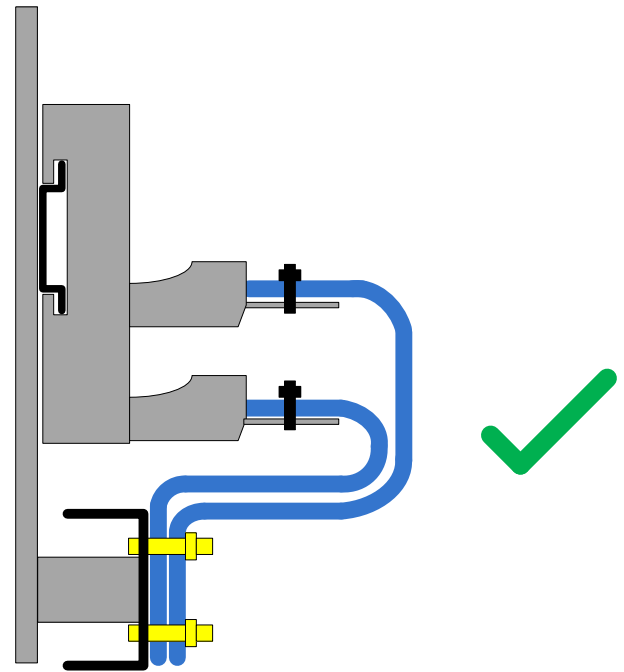

!!! CABLES SHOULD BE TIED BACK TO THE EMC RAIL SO NO UNDUE PRESSURE CAN BE EXERTED ON THE PLUGS **!!!**

The hanger

The hanger is a fabricated galvanised steel bracket custom made for the Can-X application. The last 75mm of the hanger has a rubberised coating to stop the loom cores chaffing when fitted. Additional hangers should be fitted at intermediate floors when the hang exceeds 30m.

Hanger installation

The loom should be fixed to the hanger as detailed in the following diagram.

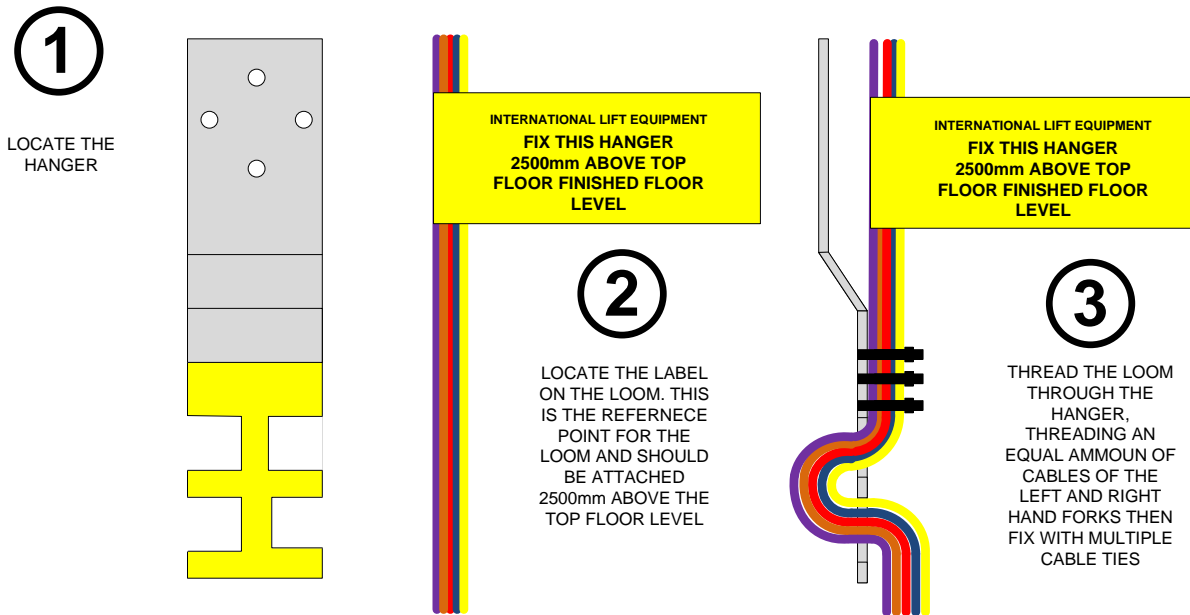

The loom and hanger should then be fitted into the trunking using fixings appropriate for the weight of the loom (not supplied) at a distance of 2.5m from the top floor finished floor level as detailed in the following diagram.

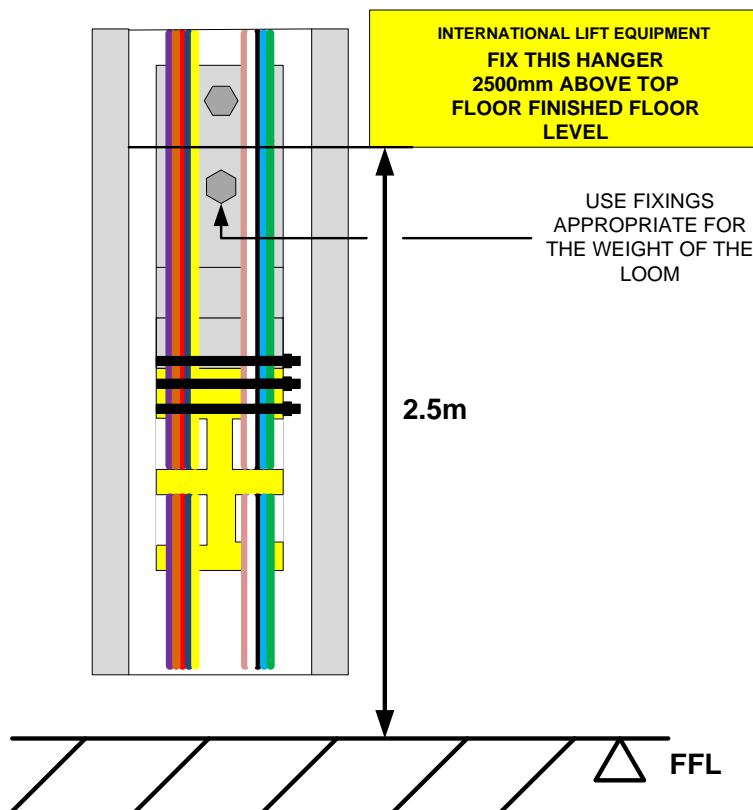

Loom tap off sockets

The loom is fitted with sockets for the following peripheral devices:

- Top limit array
- Landing lock connections
- Pre-lock connections (manual gates only)
- Bottom limit array
- Pit safety circuit connections
- Landing push connections
- Landing indicator connections
- Optional equipment

Correct tap off loom fitment

The tap off looms should be cut to the correct length at the peripheral end but if this is not practical the excess cable can be "lost" in the trunking. This should be left hanging as shown in the left hand diagram not coiled up as shown on the right hand drawing.

NOTE: This is particularly important for the CAN data cables as excess coiling of cables can cause communication problems.

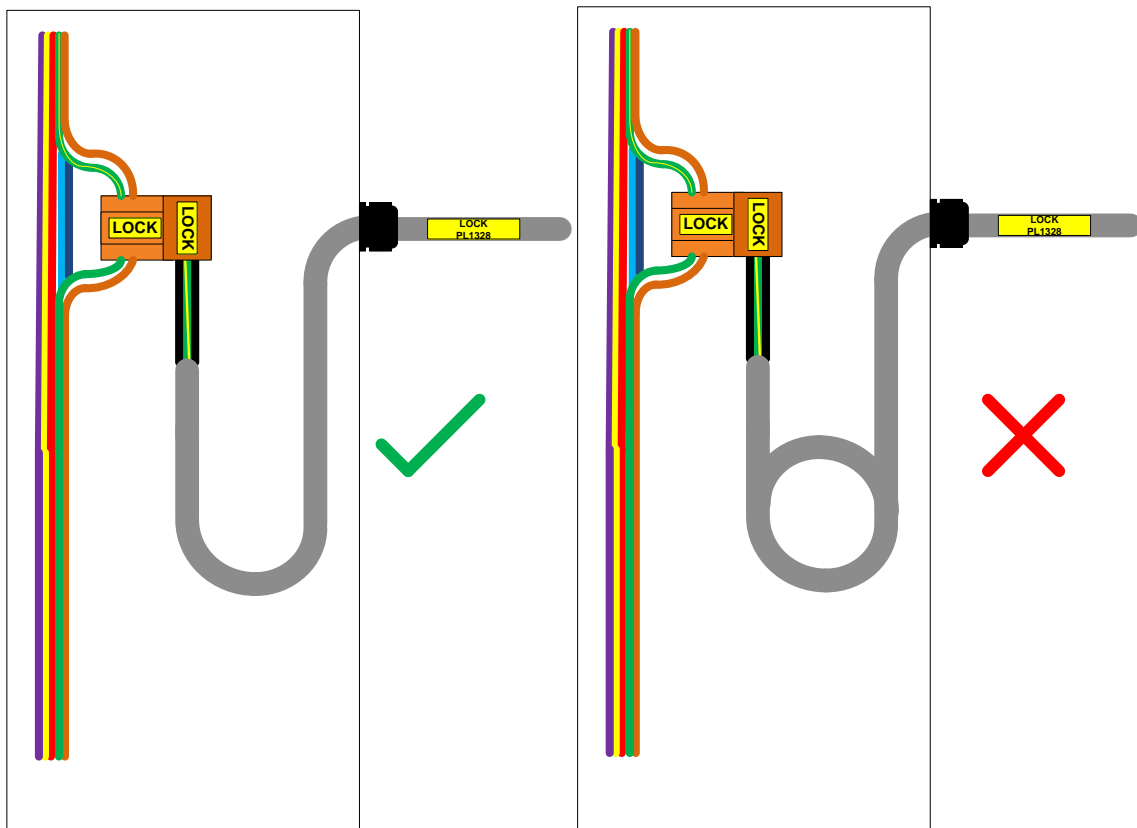

IF THE EXCESS CABLES ARE TO BE "LOST" IN THE TRUNKING THEY SHOULD BE LEFT HANGING AS ABOVE

THE EXCESS CABLE SHOULD NOT BE COILED UP AS ABOVE

Top limit array connections

The top limit array loom is supplied as a single multi core cable fitted with 2 plugs to connect to the main loom. The plugs are marked as **TLL1** and **TLL2** the loom has a part number of **PL1332**. Details of how to connect this loom to the limits are on the **R2** drawing and are also detailed in the drawing below.

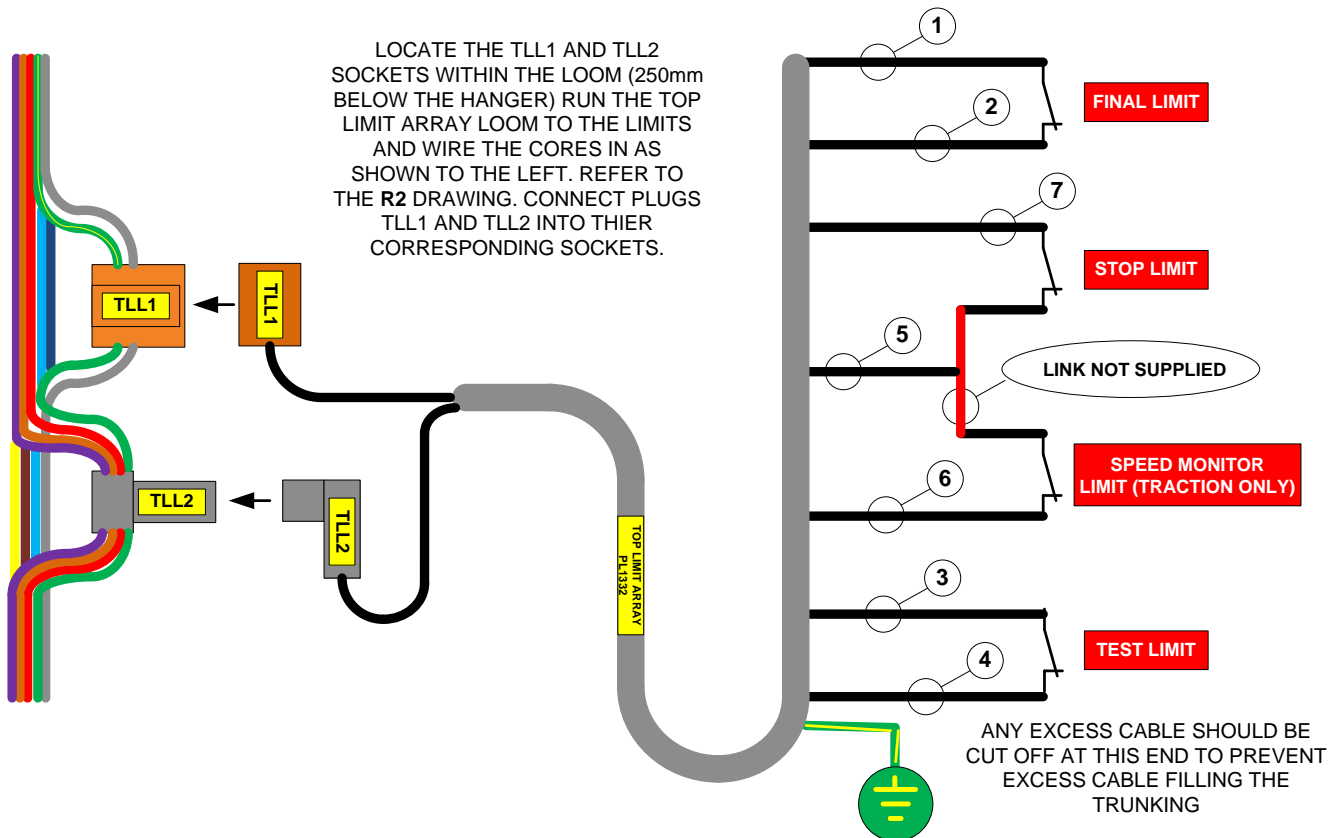

NOTE: The ILE limit arrays limits are marked as LS1, 2, 3, and 4. We do NOT mark the corresponding limit number on the drawing (only it's function) as the array can be fitted either way round depending on the installation. (So LS1 would become LS4 and vice versa)

Lock connections

The lock connection looms are supplied as single multi core cables per floor fitted with a plug to connect to the main loom. The plugs are marked **LOCK** the loom has a part number of **PL1328**. Details of how to connect this loom to the locks are on the **R2** drawing and are also detailed in the drawing below.

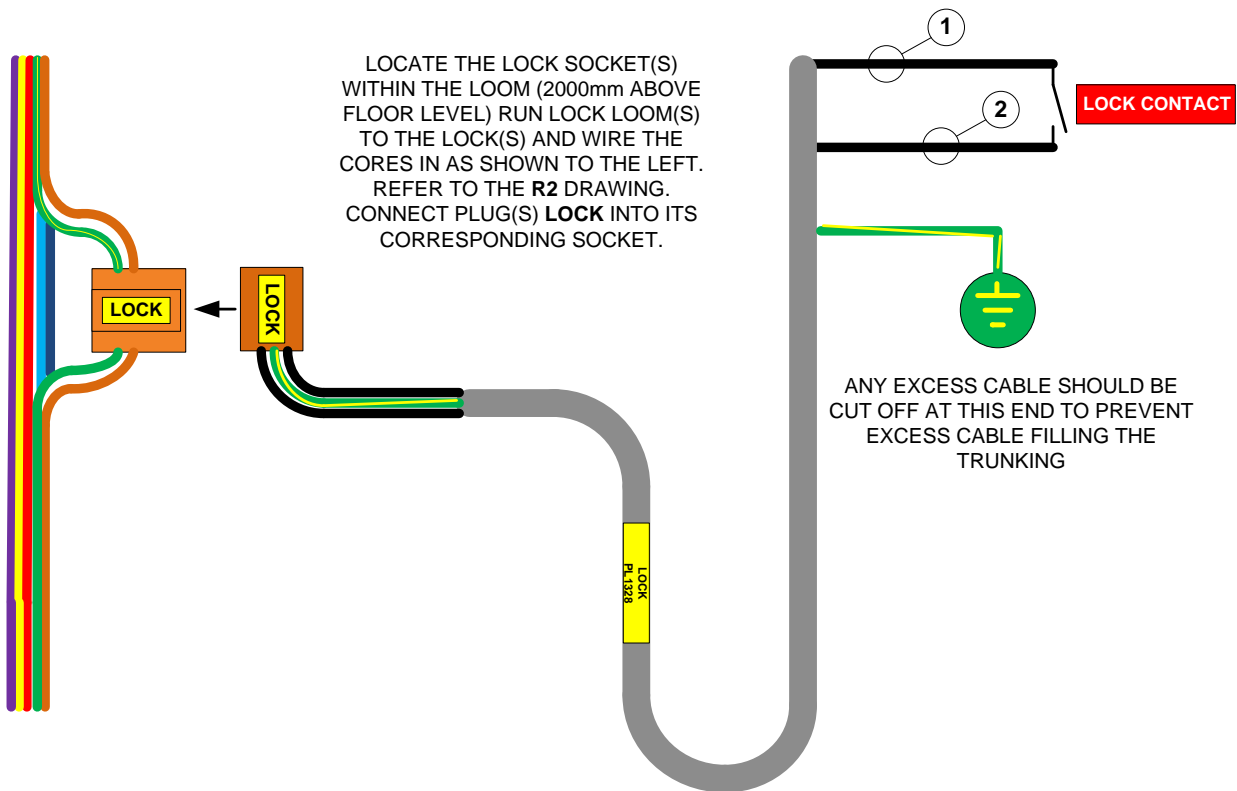

Pre lock connections (manual gates only)

The lock connection looms are supplied as single multi core cables per floor fitted with a plug to connect to the main loom. The plugs are marked **LOCKED**. Details of how to connect this loom to the locks are on the **R2** drawing and are also detailed in the drawing overleaf.

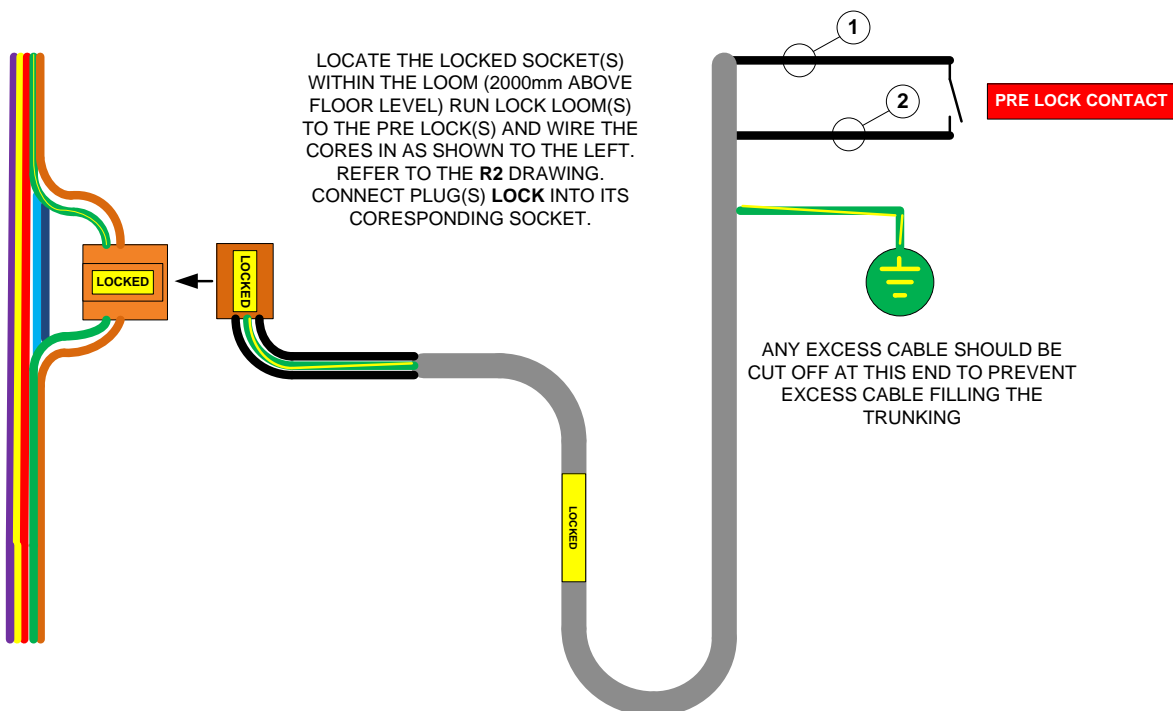

Bottom limit array connections

The bottom limit array loom is supplied as a single multi core cable fitted with a plug to connect to the main loom. The plug is marked as **BLL** and the loom has a part number of **PL1335**. Details of how to connect this loom to the limits are on the **R2** drawing and are also detailed in the drawing below.

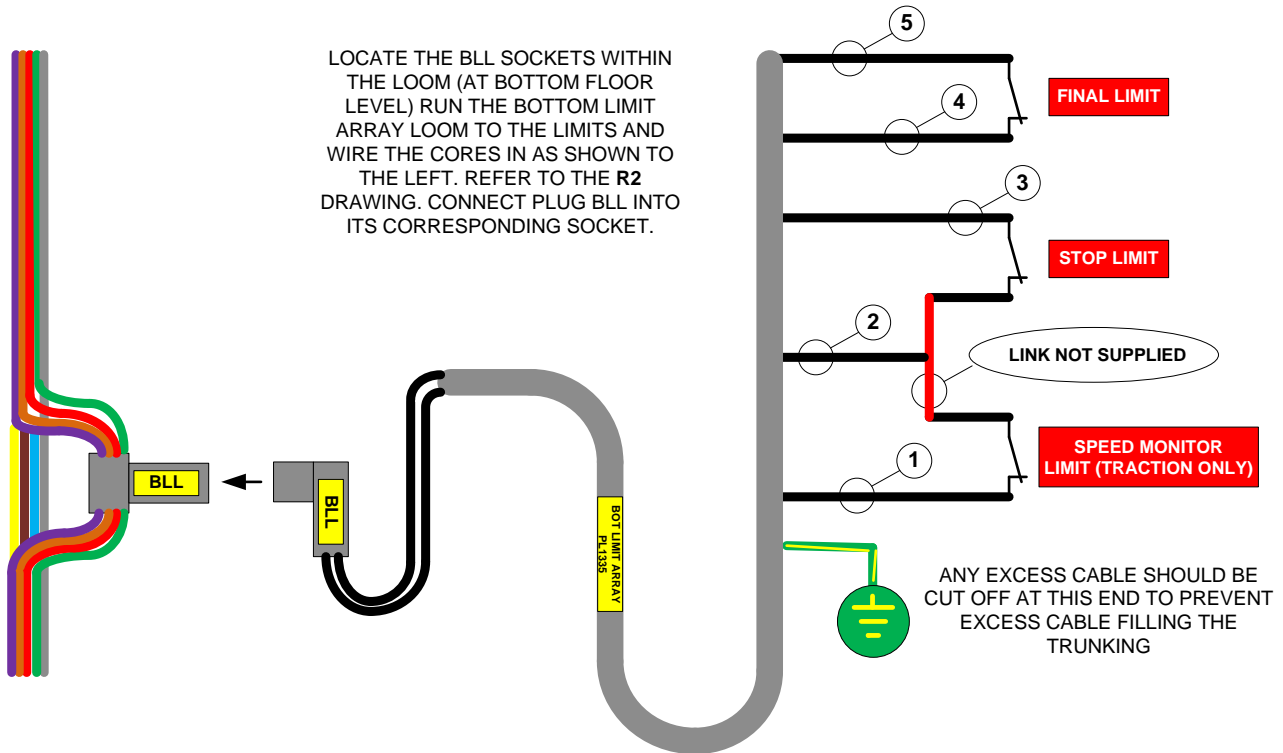

Pit safety circuit connections

The pit safety circuit loom comes in 2 guises. 1 loom caters for sites with hydraulic buffers and the other caters for those sites without. The loom is supplied with 3 or 5 multi core cables fitted with plugs to connect to the main loom. The plugs are marked as **OSGL** and **PSWL** and the looms have a part number of **PL1333 (with buffers)** and **PL1334 (without buffers)**. Details of how to connect these looms to the pit safety circuit are on the **R2** drawing and are also detailed in the drawing below.

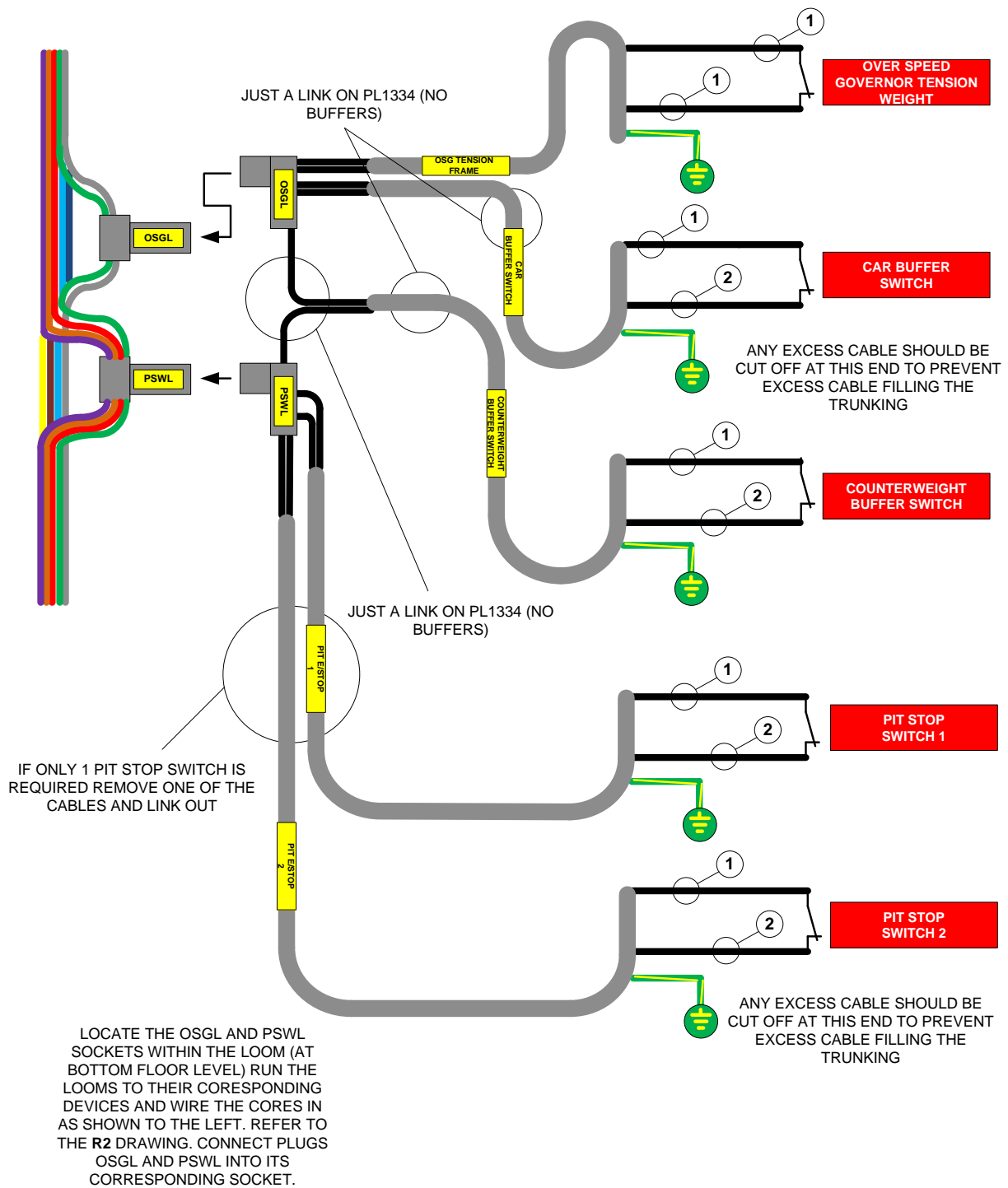

Landing push connections, Landing indicator connections

The landing push and the landing indicator share a common loom type. The loom is supplied with a multi core cable and a twisted shielded pair cable fitted with a plug to connect to the main loom. The plugs are marked as **LIPL** and the looms have a part number of **PL1329**. Details of how to connect these looms to landing nodes and indicators are on the **R3** drawing and are also detailed in the drawing below and overleaf.

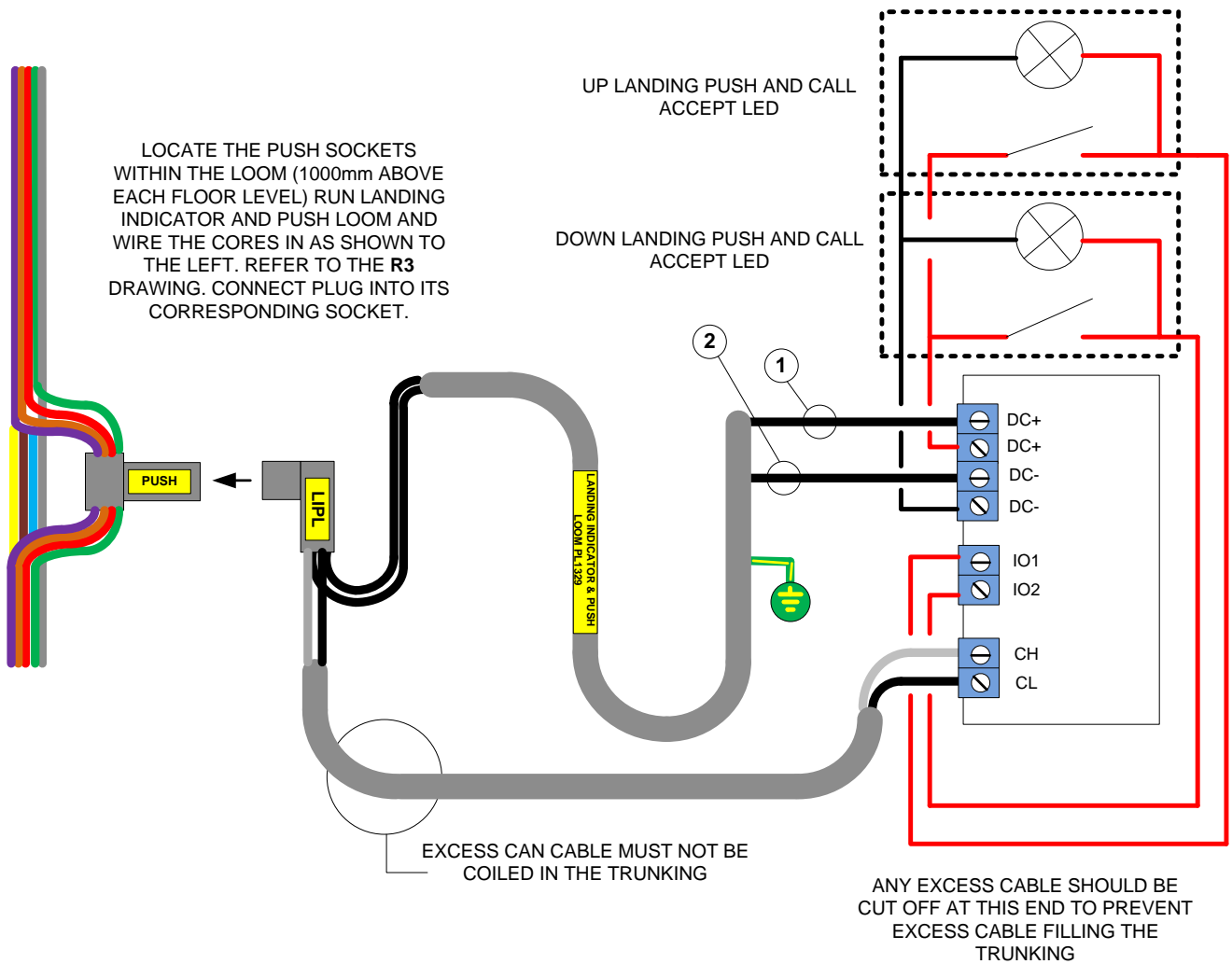

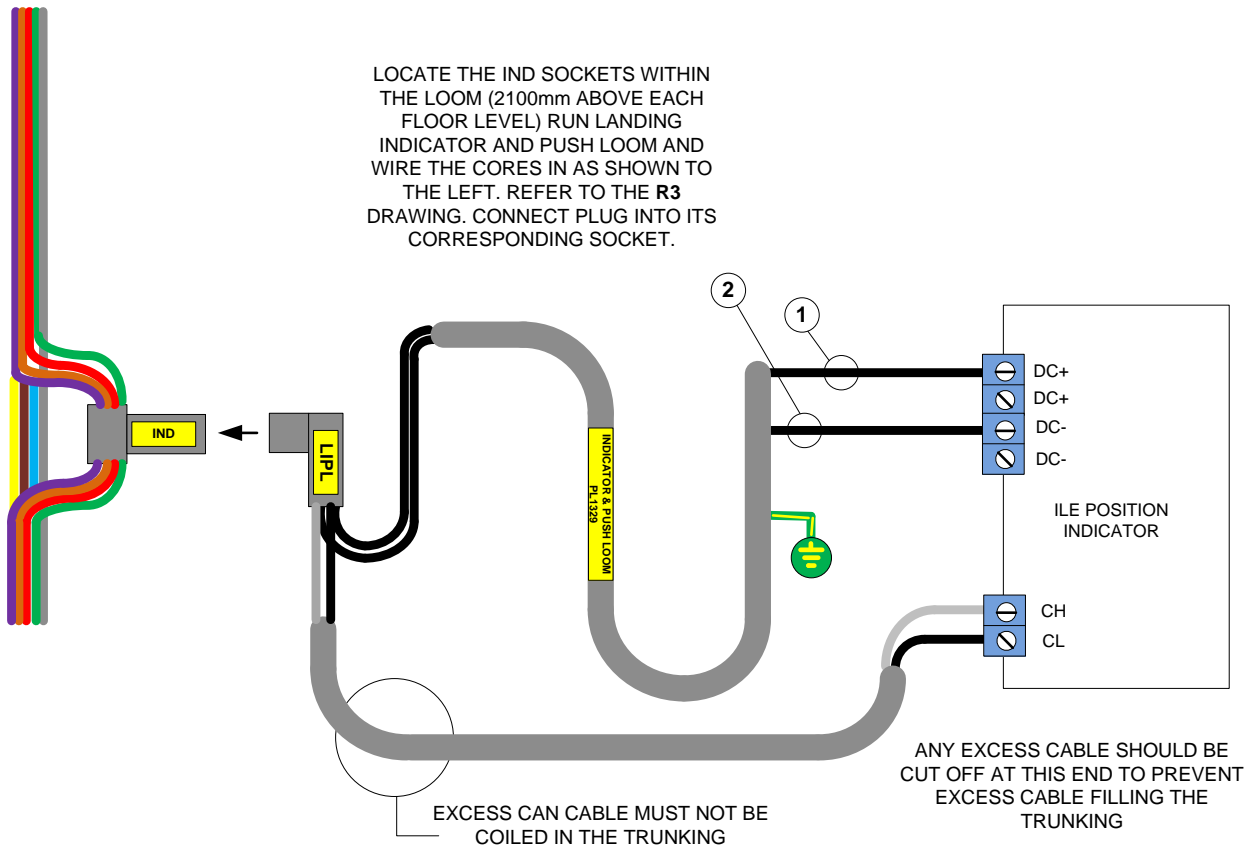

Connecting the shaft loom to the controller

The shaft loom connects to the controller into sockets X9, X10, X11, X12 and X13 as detailed in the diagram below.

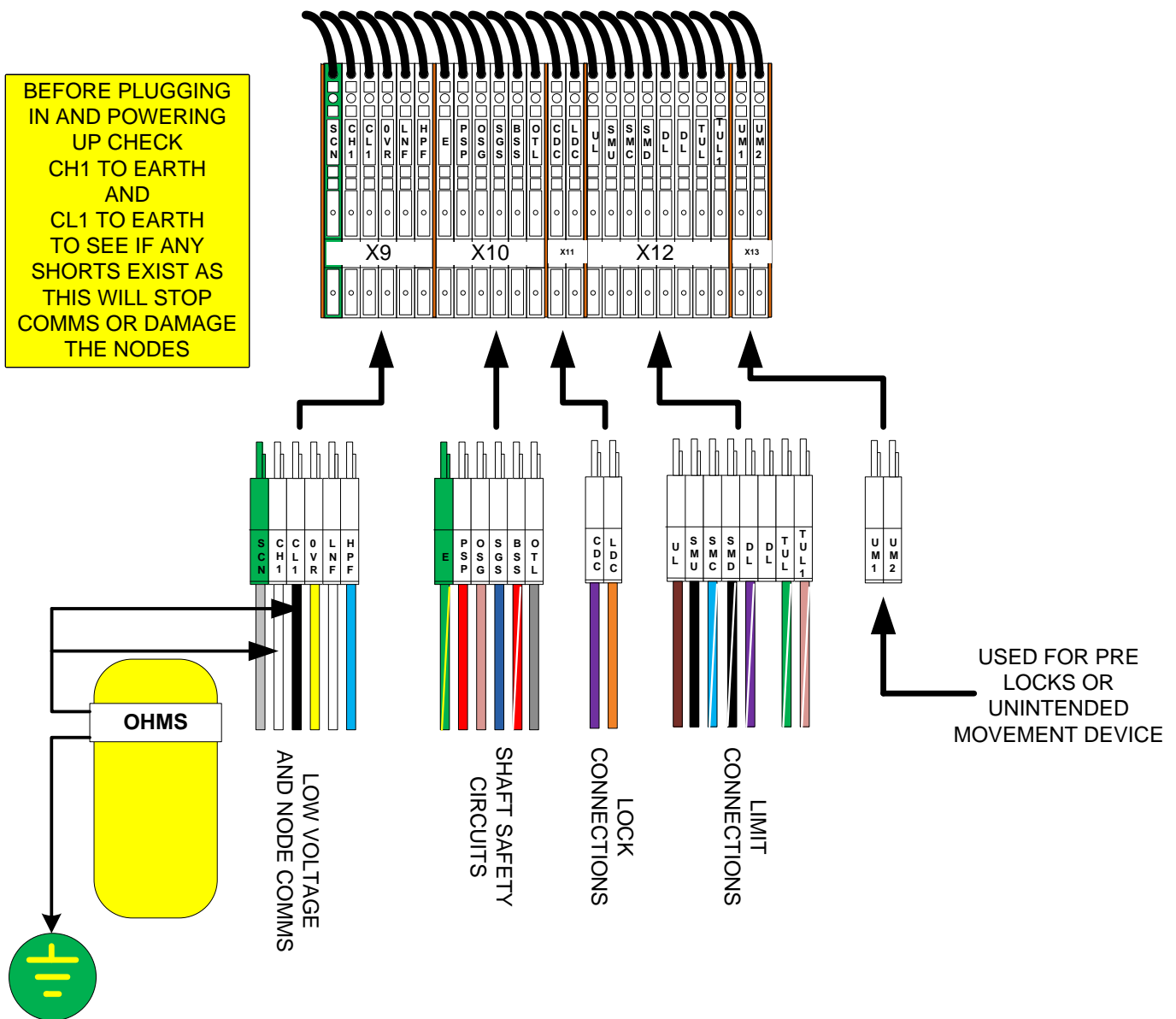

Motor room connections

Most of the motor room connections have been dealt with in the quick start section of this manual. The pre-wired loom system caters as standard for a motor room emergency stop and the over speed governor switch. These are located on plug X14. Other motor room connections are catered for but do **NOT** come with any looms, these are the car light supply terminals and the fire return signal. These have to be hard wired into terminals provided at X15 and X16 of the controller terminal rail. The connections for all these items can be found on the **R1** drawing and are also detailed in the drawing overleaf.

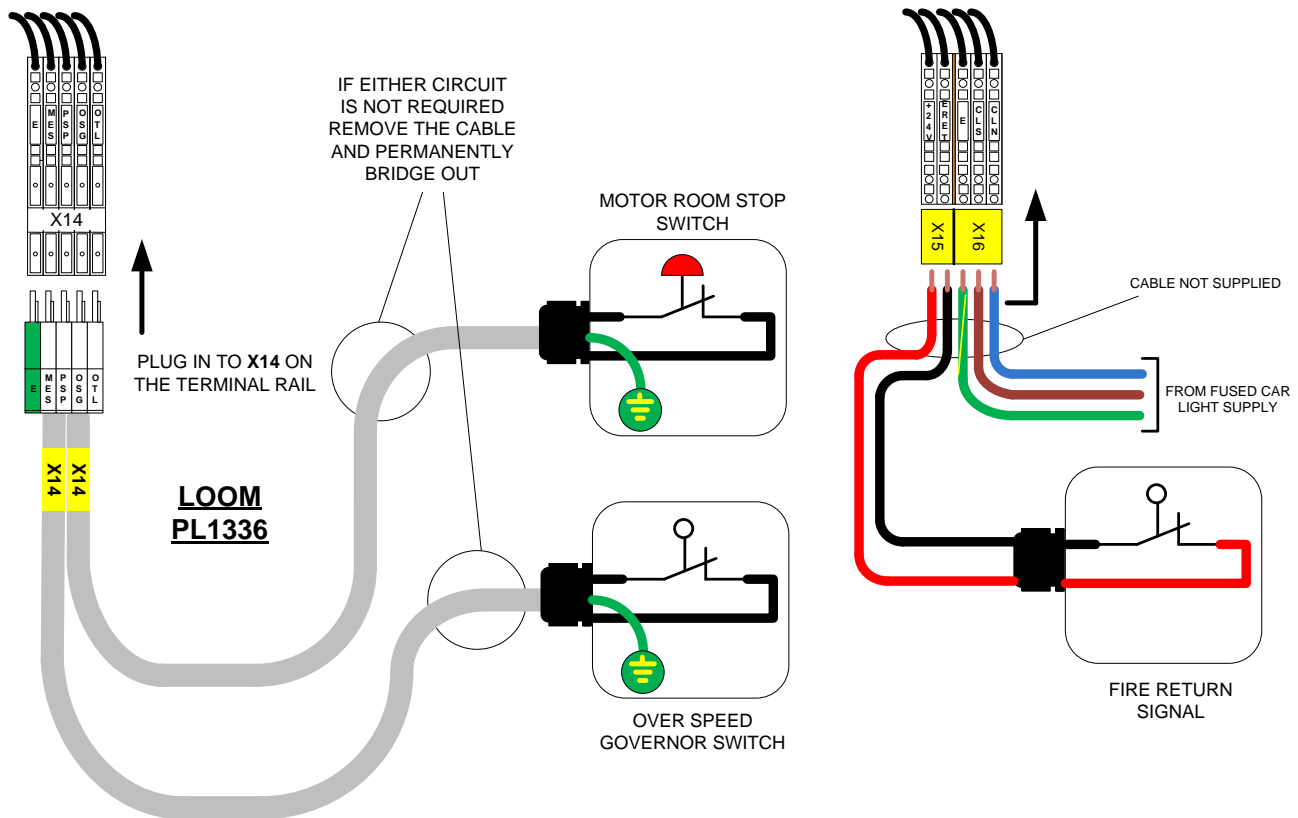

Trailing flex

The trailing flex comes pre-stripped and cut to the length specified at the time of the survey and is fitted with plugs for direct connection between the control panel and the car top I/O unit's terminal rails. The flex cores are divided in three sections and are marked with the section of terminal rail they plug into. The control panel connections are marked with an X and the car top I/O's with a Y and the trailing flex is marked "car top end" or "controller end" for ease of identification. In actual fact it can be connected either way around but to keep the correct nomenclature the X and Y connections should be observed. The flex is split into 3 sections, low voltage and non switching high voltage (cables 1-11+Earth), data (2 twisted pairs) and high voltage (cables 12-24). There are spare cores and a spare twisted pair. The flex is wound so the controller end is the 1st off the reel. On request the flex can be wound the opposite way if the installer prefers. The trailing flex connections can be found at **X6, X7 and X8** on the controller terminal rail and at **Y4, Y7 and Y8** on the car top I/O unit's terminal rail. The connections are detailed on the **R1** drawing and a visual representation of the trailing flex is shown overleaf.

If the trailing flex is too long for the installation it can be cut and stripped to the desired length. The core numbers to re-make the ends are detailed on the **R1** drawing.

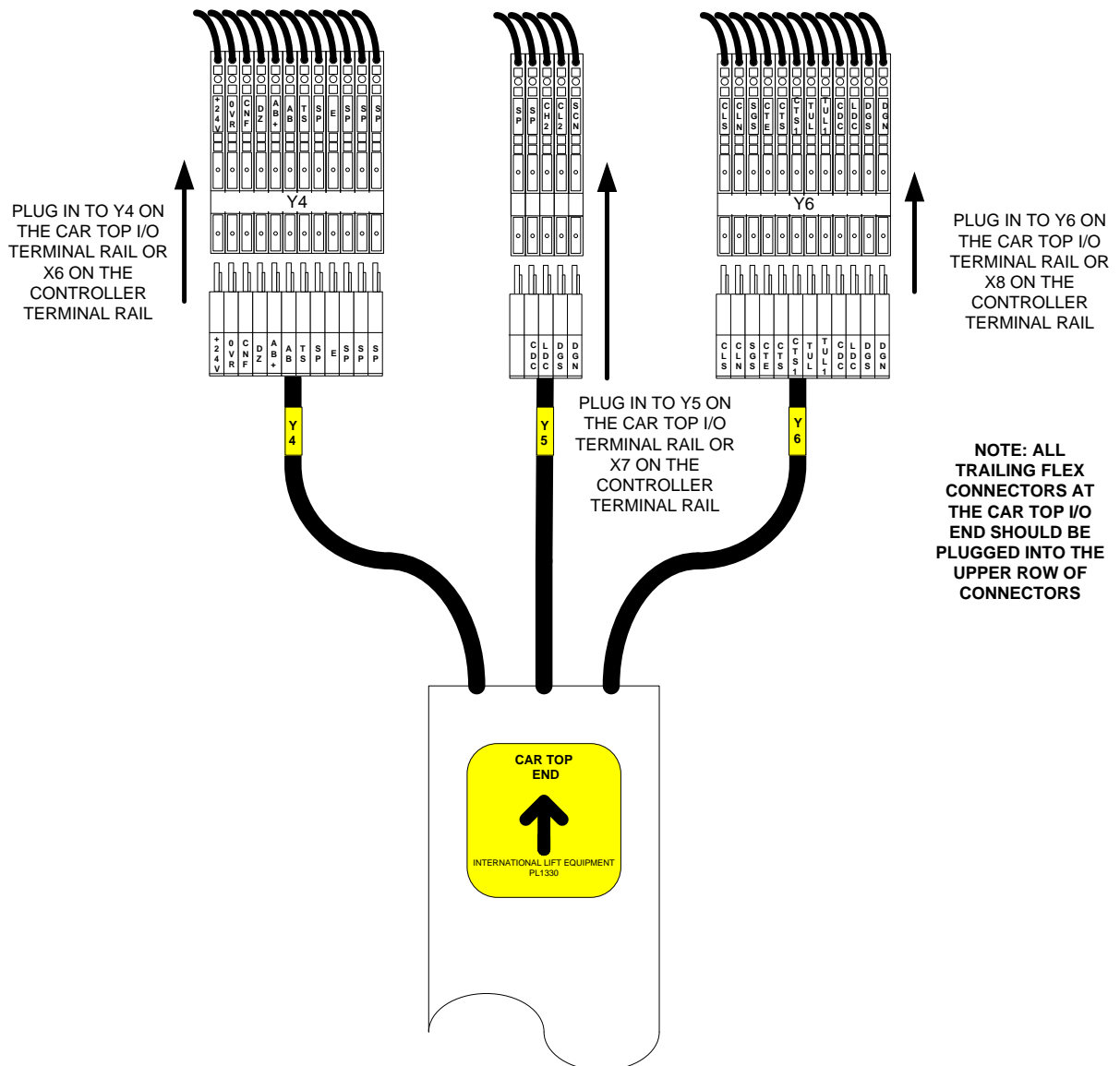

Car top I/O and looms

A car top I/O and connection box is supplied with looms for the following items:

- Car top control (pre-wired to the car top control if an ILE car top control is ordered)
- Detector edge
- Load weighing unit
- Car gate contact
- Safety gear switch
- Car lights
- COP I/O connections
- Proximity switches / tape head (pre-wired to the tape head if an ILE tape head is ordered)
- Door operators either generic VF or specific for ILE supplied door operators.

Most of the car looms are of the open ended type i.e. they are just bare wires at the peripheral end for wiring into your existing equipment. Please ensure they are wired at the destination end **BEFORE** connecting to car top I/O unit especially if the trailing flex is already connected. To keep the car top I/O unit as small as possible some of the connections are double socket types. All earth connections from each loom need to be hard wired into the earth connections at either end of the terminal rail.

All car top loom connections can be found on drawing **R4** and are detailed in the following sequence of diagrams.

General do's and don'ts

- DO always plan ahead the cable runs into the car top I/O unit to make cable entry neater.
- DO always plan the routing of cables on the car top to offer the best possible mechanical protection.
- DO always replace the lid of the car top I/O unit whenever possible to stop the ingress of swarf.
- DO always follow your company's health and safety policy when working on the car top.
- DO try to mount the car top I/O unit VERTICALLY. (See following diagram).
- NEVER connect any of the car top equipment with the trailing flex plugged into a live controller.
- NEVER leave any undue strain on the cables once fitted to the car top I/O. (See diagram overleaf)

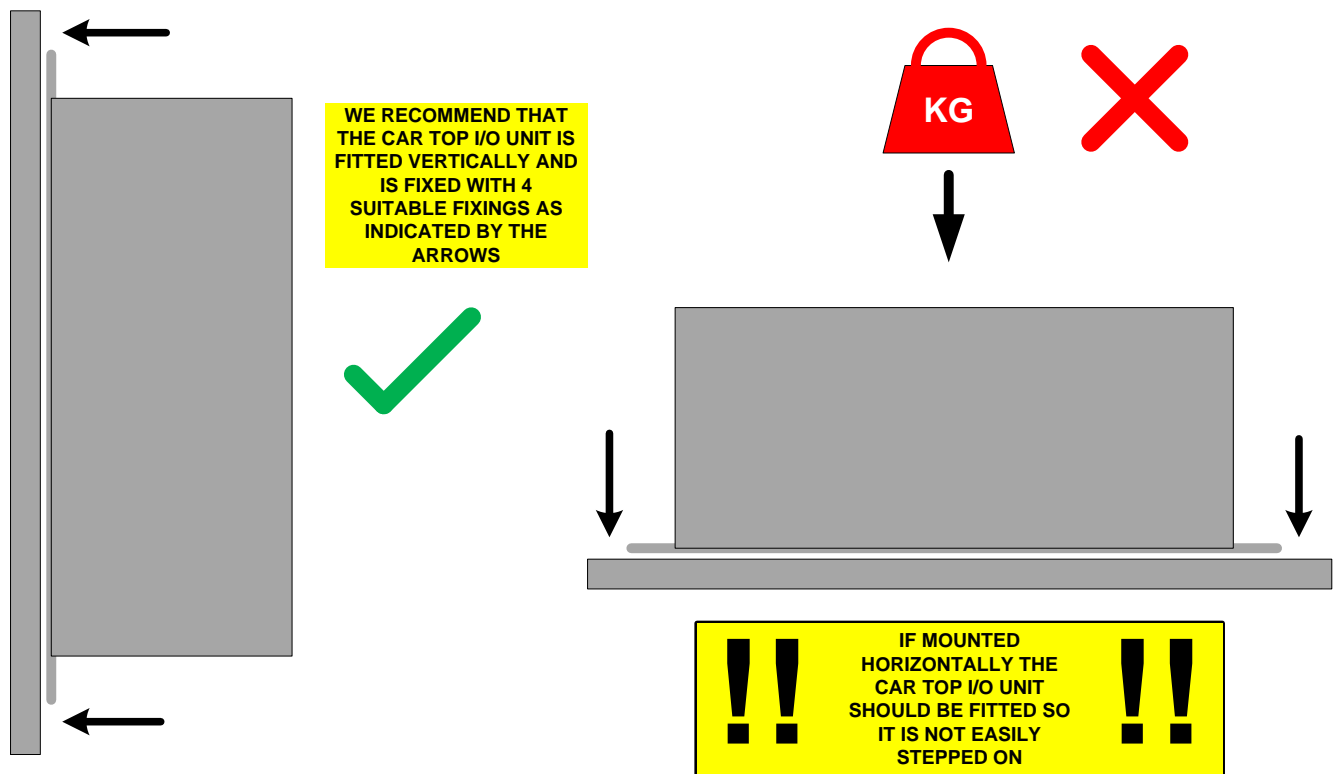

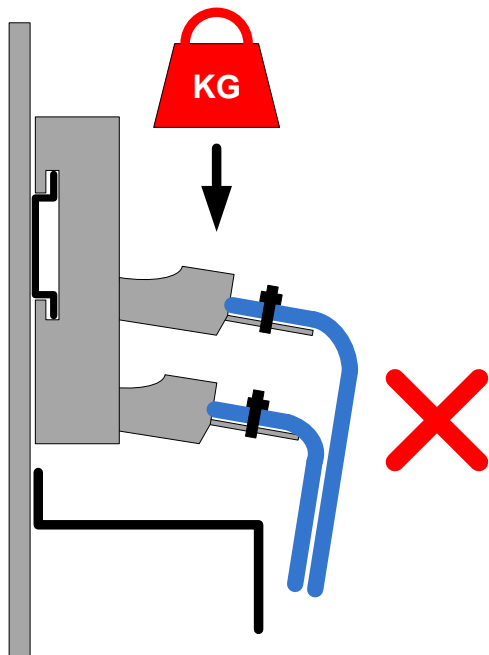

!!! PLUGS SHOULD NOT BE LEFT SO THE WEIGHT OF THE CABLE CAN CAUSE UNDUE PRESSURE ON THE CONNECTION !!!

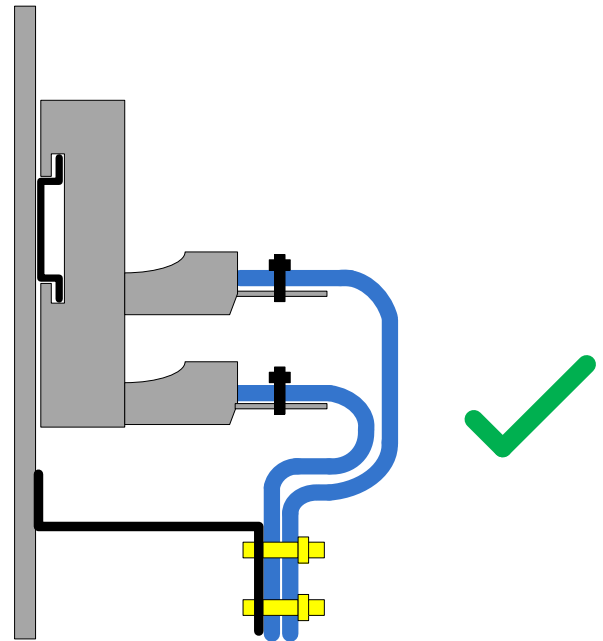

!!! CABLES SHOULD BE TIED BACK TO THE EMC RAIL SO NO UNDUE PRESSURE CAN BE EXERTED ON THE PLUGS !!!

Car top peripheral connections

The following instructions deal with connecting the car top peripheral devices to the car top I/O unit.

Car top control and door gear connections

The car top control is supplied pre-wired (if ordered) or a loom for connection to your existing car top control is supplied. The part number for the car top control loom is **PL1320L** and the part number for the pre-wired car top control is **PL1320**. For connection to your existing car top control refer to the **R4** drawing.

The door operator loom is supplied for VF door operators is supplied in 2 different guises, either generic to suit most VF operators or specific for ILE supplied door operators. See the spare part section of this manual for specific part numbers. Any other type of operator would have a custom loom. The door operator connection can be found on the **R4** drawing.

The drawing overleaf shows the car top control and door operator connection points on the car top I/O terminal rail.

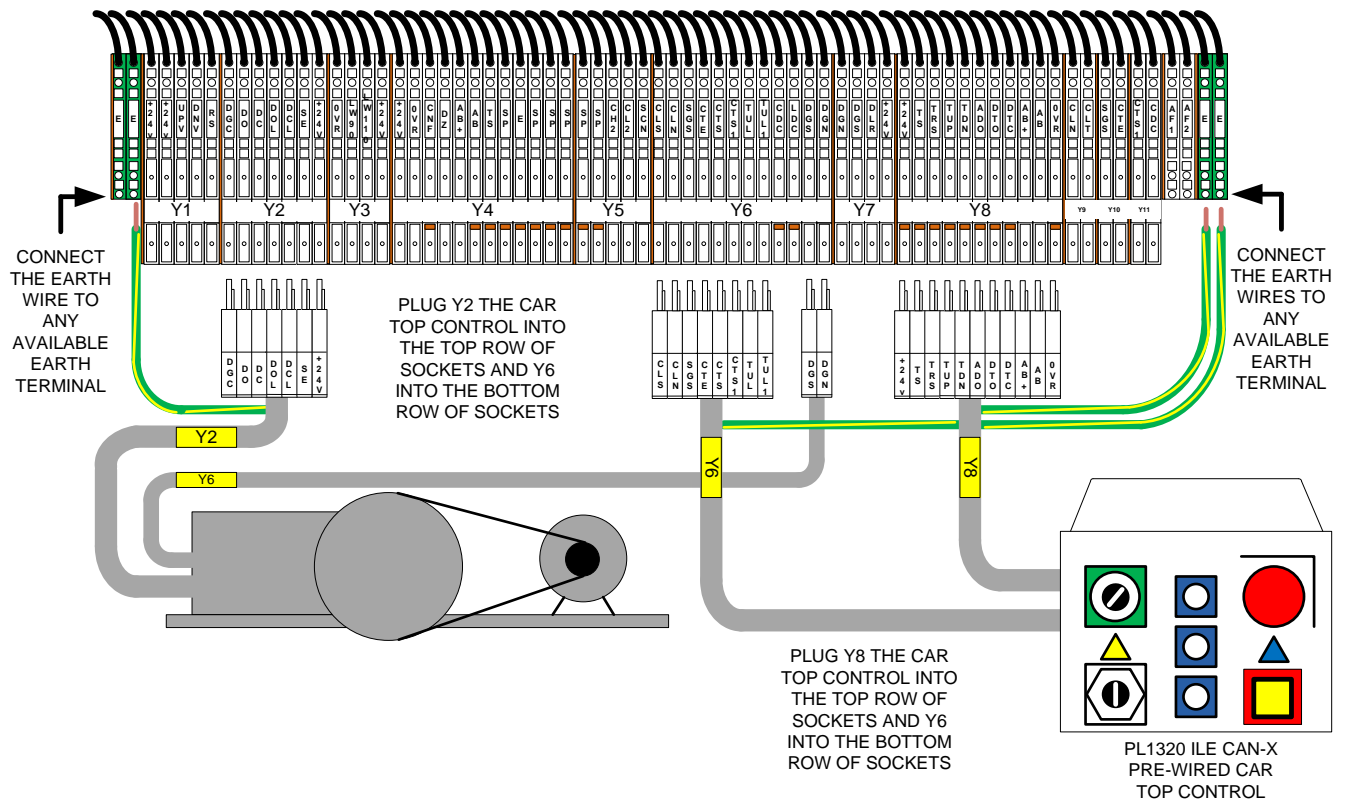

Car gate switch, safety gear switch, car lights, load weighing and COP loom connections

The car gate switch, safety gear switch and the car lights connections are achieved using the supplied 3 core cables. They connect into **Y11**, **Y10** and **Y9** respectively on the car top I/O terminal rail and the loom part numbers are **PL1340**, **PL1341** and **PL1342**.

The COP has a 5 core cable and a shielded twisted pair cable it comes pre-wired to the COP I/O din rail ready to mount in the COP. It plugs into **Y4**, **Y5** and **Y8**.

The load weighing connections are achieved using a 5 core cable. It connects to **Y3** on the car top I/O terminal rail and the loom part number is **PL1339**. (This is prepared for the LLEC5 and 6 load weighing units supplied by ILE if any other unit or supply voltage is required contact ILE for support)

Refer to the **R4** drawing for the connections and core numbers. The drawing overleaf shows their connection points on the car top I/O terminal rail.

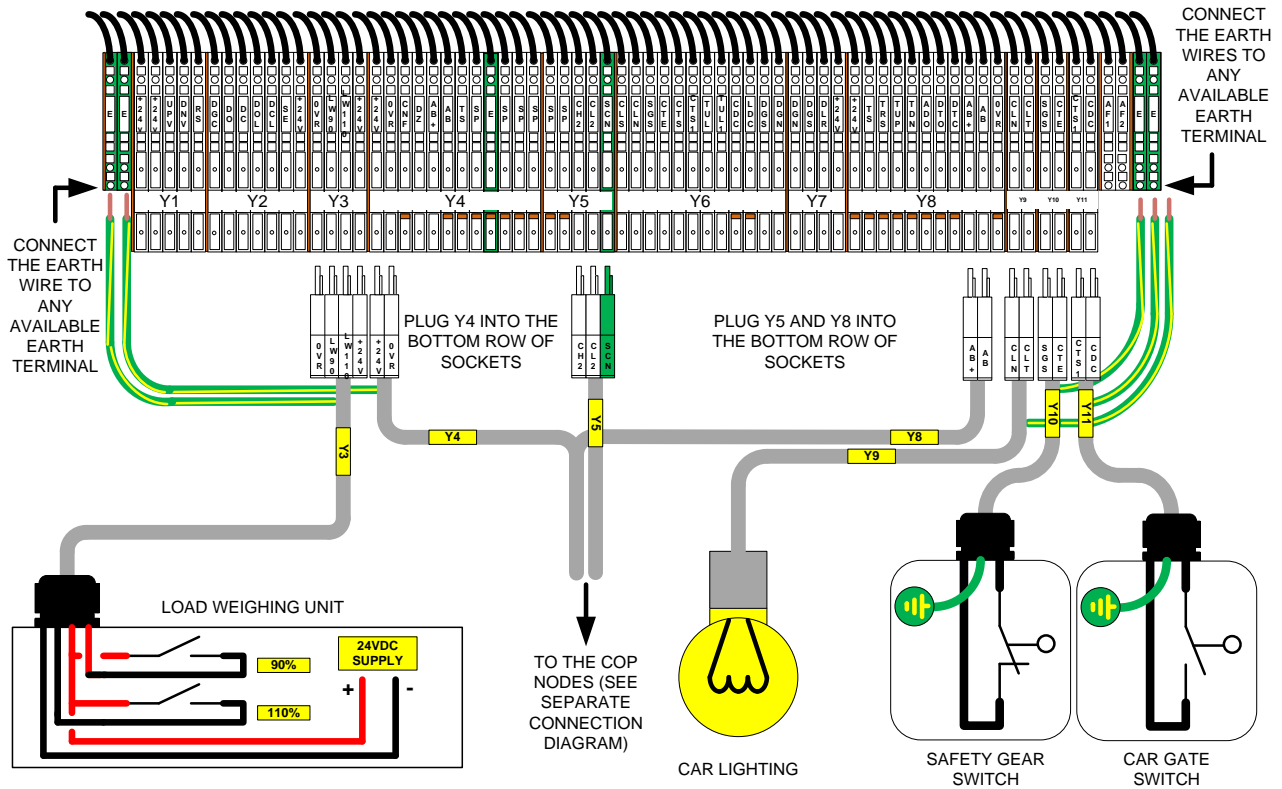

Door light ray and position system connections

The Can-X system uses either proximity switches or a tape head system for positioning. It can also be ordered with a Schmersal USP. In this case the connection of the programming interface is pre-wired by ILE. The car top I/O rail is pre-prepared for the former and the proximity switches are pre-wired and come as a complete kit. Their part number is **PL1345**. If a tape head is required this should be ordered as a prewired unit and 4 extra terminals are added to the car top I/O rail to support the unit. Connections for either system are detailed on the **R4** drawing and the drawing overleaf shows their connection points on the car top I/O terminal rail.

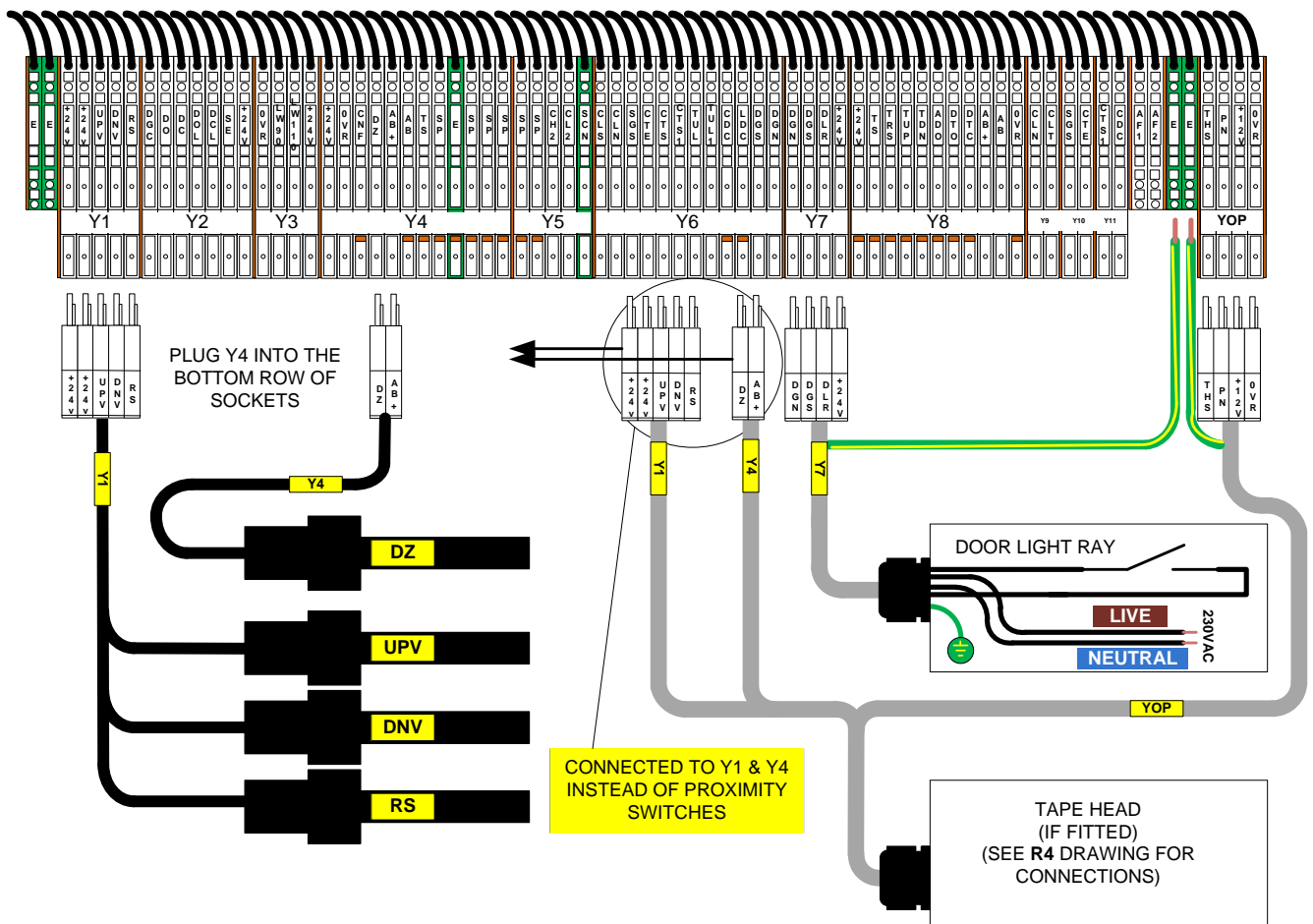

COP connections

The I/O for the COP (car pushes, Door open push, Door Close push and Service control) are fitted to a din rail for mounting behind the COP. The din rail also includes the ILE serial speech unit (if ordered). This complete unit is pre wired to the COP loom for plugging directly into the car top I/O unit. Wires are included in the loom for connecting to the alarm push and to an ILE position indicator. The car pushes then have to be hard wired into the node(s). (The wiring is not included unless pre-wired by ILE)

All COP I/O connections can be found on drawing **E4**

The COP connections can be found at **Y4**, **Y5** and **Y78** on the car top I/O unit's terminal rail.

NOTE: The COP loom does not contain any wires for auto diallers or pictograms.

Panel test connections

The Skycom CAN-X controller comes as standard with panel test. This is achieved by using a cable mounted plug in unit. The unit has 1 Metre of cable fitted so the machine can be observed whilst using panel test. The lift will NOT run on normal if the panel test unit is unplugged. The quick start up kit plugs into the same connection as this so it must be unplugged to fit the panel test unit.

The panel test connection can be found at **X5** on the controller terminal rail.

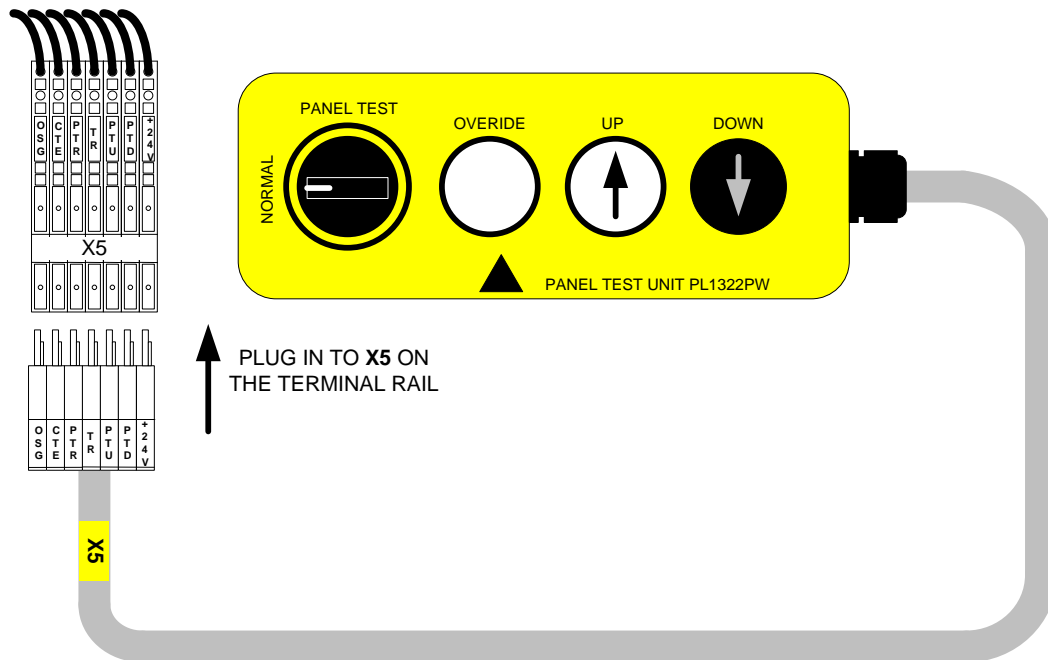

Technical support

ILE technical support can be contacted if any problems occur or advice is needed during installation. They can be contacted on:

0116 2690900 Monday – Thursday 8-30am – 5.00pm and Friday 8.30am – 4.00pm

Notes